

# **marantz®**

## **Model SR5200 User Guide**

---

AV Surround Receiver

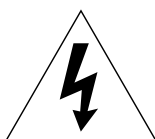
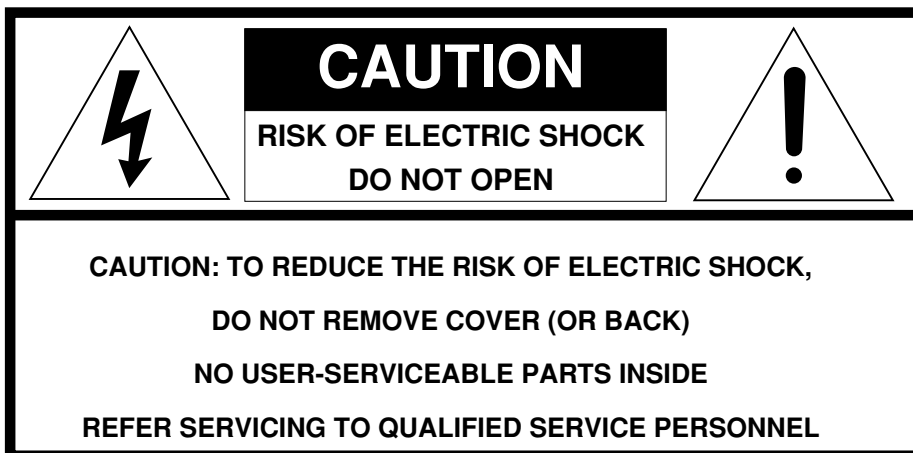

The lightning flash with arrowhead symbol, within an equilateral triangle, is intended to alert the user to the presence of uninsulated “dangerous voltage” within the product’s enclosure that may be of sufficient magnitude to constitute a risk of electric shock to persons.



The exclamation point within an equilateral triangle is intended to alert the user to the presence of important operating and maintenance (servicing) instructions in the literature accompanying the appliance.

## WARNING

**TO REDUCE THE RISK OF FIRE OR ELECTRIC SHOCK,  
DO NOT EXPOSE THIS APPLIANCE TO RAIN OR MOISTURE.**

**CAUTION: TO PREVENT ELECTRIC SHOCK, MATCH WIDE  
BLADE OF PLUG TO WIDE SLOT, FULLY INSERT.**

**ATTENTION: POUR ÉVITER LES CHOCS ÉLECTRIQUES,  
INTRODUIRE LA LAME LA PLUS LARGE DE LA FICHE DANS LA  
BORNE CORRESPONDANTE DE LA PRISE ET POUSSER  
JUSQU’AU FOND.**

### NOTE TO CATV SYSTEM INSTALLER:

This reminder is provided to call the CATV (Cable-TV) system installer’s attention to Article 820-40 of the NEC, that provides guidelines for proper grounding and, in particular, specified that the cable ground shall be connected to the grounding system of the building, as close to the point of cable entry as practical.

### NOTE:

This equipment has been tested and found to comply with the limits for a Class B digital device, pursuant to Part 15 of the FCC Rules. These limits are designed to provide reasonable protection against harmful interference in a residential installation. This equipment generates, uses and can radiate radio frequency energy and, if not installed and used in accordance with the instructions, may cause harmful interference to radio communications. However, there is no guarantee that interference will not occur in a particular installation. If this equipment does cause harmful interference to radio or television reception, which can be determined by tuning the equipment off and on, the user is encouraged to try to

correct the interference by one or more of the following measures:

- Reorient or relocate the receiving antenna.
- Increase the separation between the equipment and receiver.
- Connect the equipment into an outlet on a circuit different from that to which the receiver is connected.
- Consult the dealer or an experienced radio/TV technician for help.

### NOTE:

Changes or modifications may cause this unit to fail to comply with Part 15 of the FCC Rules and may void the user’s authority to operate the equipment.

# IMPORTANT SAFETY INSTRUCTIONS

## READ BEFORE OPERATING EQUIPMENT

This product was designed and manufactured to meet strict quality and safety standards. There are, however, some installation and operation precautions which you should be particularly aware of.

1. Read Instructions - All the safety and operating instructions should be read before the appliance is operated.
2. Retain Instructions-The safety and operating instructions should be retained for future reference.
3. Heed Warnings-All warnings on the appliance and in the operating instructions should be adhered to.
4. Follow Instructions-All operating and use instructions should be followed.
5. Cleaning-Unplug this video product from the wall outlet before cleaning. Do not use liquid cleaners or aerosol cleaners. Use a damp cloth for cleaning.
6. Attachments-Do not use attachments not recommended by the video product manufacturer as they may cause hazards.
7. Water and Moisture-Do not use this video product near water-for example, near a bath tub, wash bowl, kitchen sink, or laundry tub, in a wet basement, or near a swimming pool, and the like.
8. Accessories-Do not place this video product on an unstable cart, stand, tripod, bracket, or table. The video product may fall, causing serious injury to a child or adult, and serious damage to the appliance. Use only with a cart, stand, tripod, bracket, or table recommended by the manufacturer, or sold with the video product. Any mounting of the appliance should follow the manufacturer's instructions, and should use a mounting accessory recommended by the manufacturer.
9. Ventilation-Slots and openings in the cabinet are provided for ventilation and to ensure reliable operation of the video product and to protect it from overheating, and these openings must not be blocked or covered. The openings should never be blocked by placing the video product on a bed, sofa, rug, or other similar surface. This video product should never be placed near or over a radiator or heat register. This video product should not be placed in a built-in installation such as a bookcase or rack unless proper ventilation is provided or the manufacturer's instructions have been adhered to.
10. Power Sources-This video product should be operated only from the type of power source indicated on the marking label. If you are not sure of the type of power supply to your home, consult your appliance dealer or local power company. For video products intended to operate from battery power, or other sources, refer to the operating instructions.
11. Grounding or Polarization-This video product is equipped with a polarized alternating-current line plug (a plug having one blade wider than the other). This plug will fit into the power outlet only one way. This is a safety feature. If you are unable to insert the plug fully into the outlet, try reversing the plug. If the plug should still fail to fit, contact your electrician to replace your obsolete outlet. Do not defeat the safety purpose of the polarized plug.

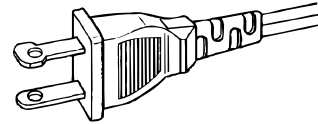

AC POLARIZED PLUG

12. Power-Cord Protection-Power-supply cords should be routed so that they are not likely to be walked on or pinched by items placed upon or against them, paying particular attention to cords at plugs, convenience receptacles, and the point where they exit from the appliance.
13. Protective Attachment Plug - The appliance is equipped with an attachment plug having overload protection. This is a safety feature. See Instruction Manual for replacement or resetting of protective device. If replacement of the plug is required, be sure the service technician has used a replacement plug specified by the manufacturer that has the same overload protection as the original plug.
14. Outdoor Antenna Grounding-If an outside antenna or cable system is connected to the video product, be sure the antenna or cable system is grounded so as to provide some protection against voltage surges and built up static charges. Section 810 of the National Electrical Code, ANSI/NFPA No. 70-1984, provides information with respect to proper grounding of the mast and supporting structure, grounding of the lead-in wire to an antenna discharge unit, size of grounding conductors, location of antenna-discharge unit, connection to grounding electrodes, and requirements for the grounding electrode. See Figure 1.
15. Lightning-For added protection for this video product receiver during a lightning storm, or when it is left un-attended and unused for long periods of time, unplug it from the wall outlet and disconnect the antenna or cable system. This will prevent damage to the video product due to lightning and power-line surges.
16. Power Lines-An outside antenna system should not be located in the vicinity of overhead power lines or other electric light or power circuits, or where it can fall into such power lines or circuits. When installing an outside antenna system, extreme care should be taken to keep from touching such power lines or circuits as contact with them might be fatal.
17. Overloading-Do not overload wall outlets and extension cords as this can result in a risk of fire or electric shock.
18. Object and Liquid Entry-Never push objects of any kind into this video product through openings as they may touch dangerous voltage points or short-out parts that could result in a fire or electric shock. Never spill liquid of any kind on the video product.

19. Servicing-Do not attempt to service this video product yourself as opening or removing covers may expose you to dangerous voltage or other hazards. Refer all servicing to qualified service personnel.
20. Damage Requiring Service-Unplug this video product from the wall outlet and refer servicing to qualified service personnel under the following conditions:
  - a. When the power-supply cord or plug is damaged.
  - b. If liquid has been spilled, or objects have fallen into the video product.
  - c. If the video product has been exposed to rain or water.
  - d. If the video product does not operate normally by following the operating instructions. Adjust only those controls that are covered by the operating instructions as an improper adjustment of other controls may result in damage and will often require extensive work by a qualified technician to restore the video product to its normal operation.
  - e. If the video product has been dropped or the cabinet has been damaged.
  - f. When the video product exhibits a distinct change in performance-this indicates a need for service.
21. Replacement Parts-When replacement parts are required, be sure the service technician has used replacement parts specified by the manufacturer or have the same characteristics as the original part. Unauthorized substitutions may result in fire, electric shock or other hazards.
22. Safety Check-Upon completion of any service or repairs to this video product, ask the service technician to perform safety checks to determine that the video product is in proper operating condition.
23. Carts and Stands-The appliance should be used only with a cart or stand that is recommended by the manufacturer.
24. An appliance and cart combination should be moved with care. Quick stops, excessive force, and uneven surfaces may cause the appliance and cart combination to overturn.



**FIGURE 1  
EXAMPLE OF ANTENNA GROUNDING ACCORDING TO  
NATIONAL ELECTRICAL CODE INSTRUCTIONS  
CONTAINED IN ARTICLE 810 - "RADIO AND TELEVISION EQUIPMENT"**

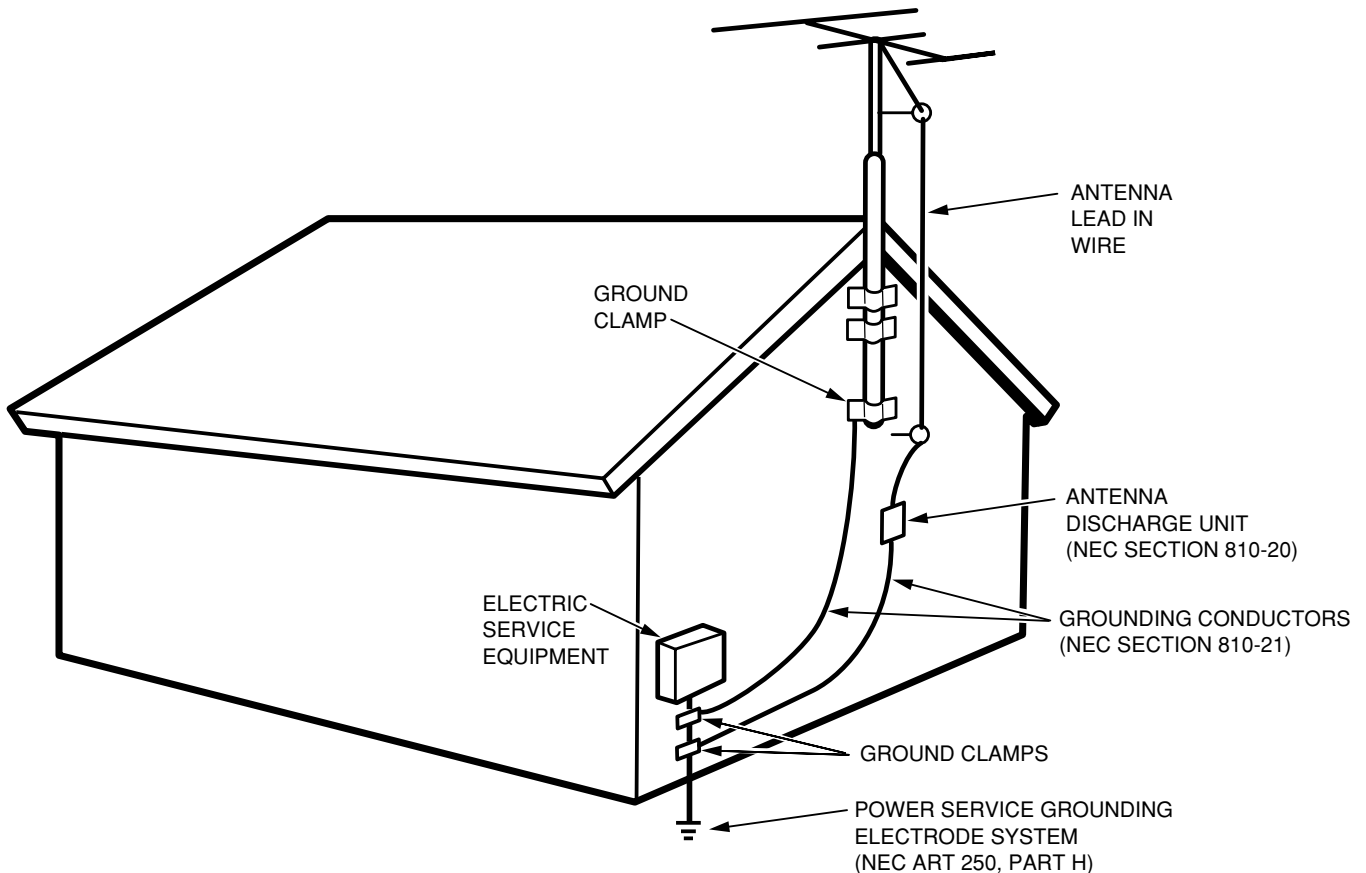

NEC - NATIONAL ELECTRICAL CODE

This Class B digital apparatus meets all requirements of the Canadian Interference - Causing Equipment Regulations.

Cet appareil numérique de la Classe B respecte toutes les exigences du Règlement sur le matériel brouilleur du Canada.

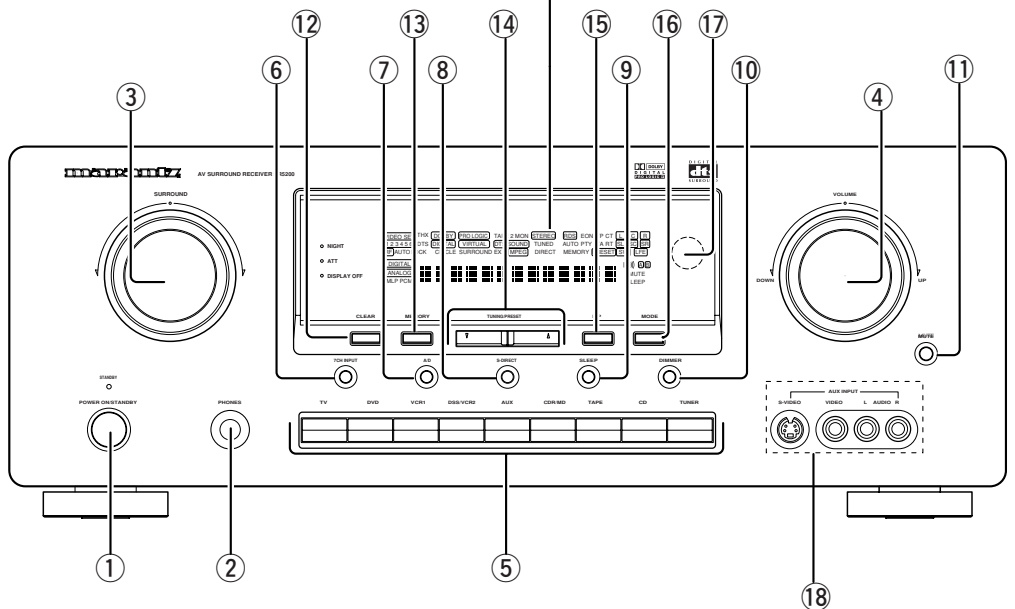
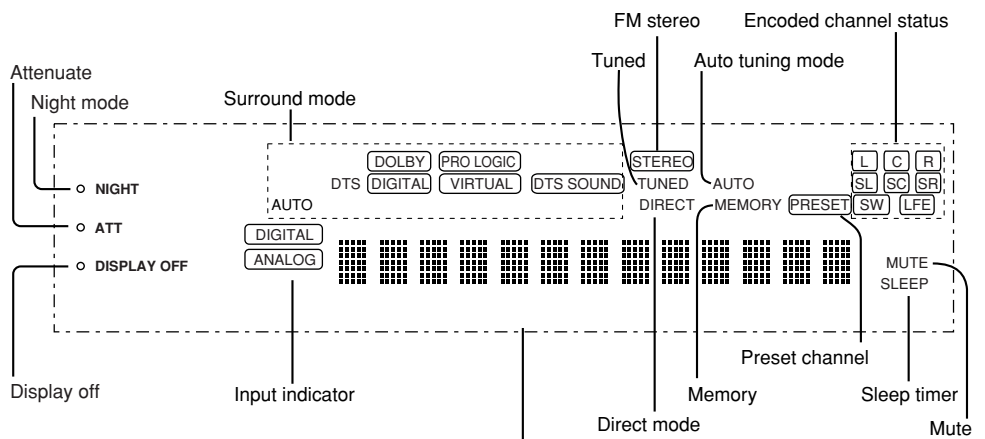
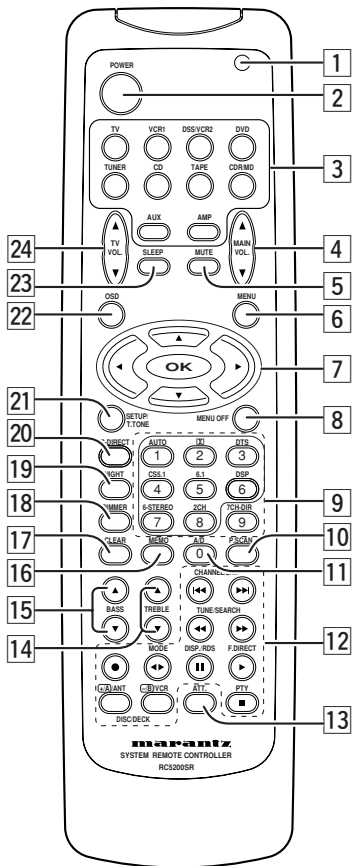
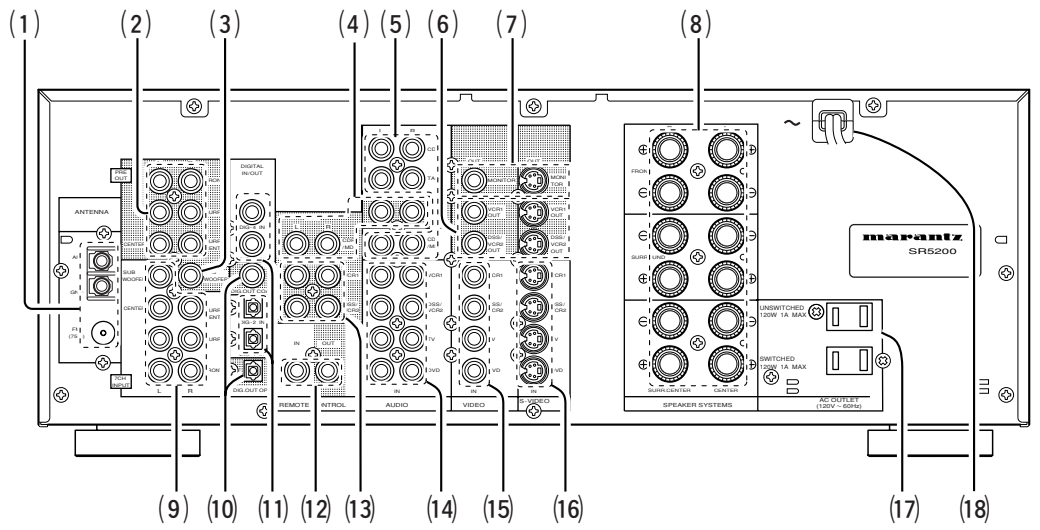

**VIDEO SYSTEM CONNECTIONS FOR VIDEO COMPONENTS**

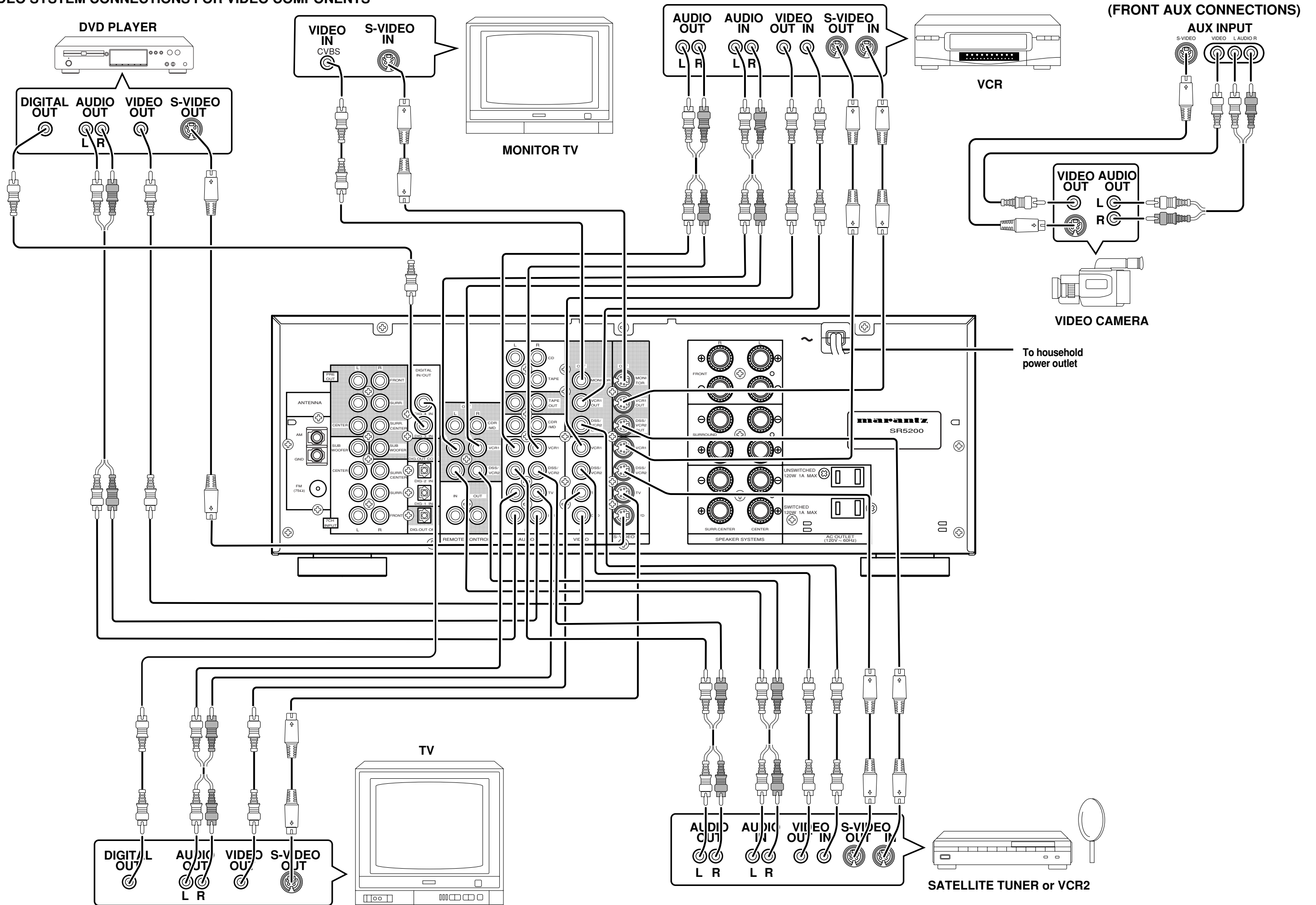

**AUDIO SYSTEM CONNECTIONS FOR AUDIO COMPONENTS**

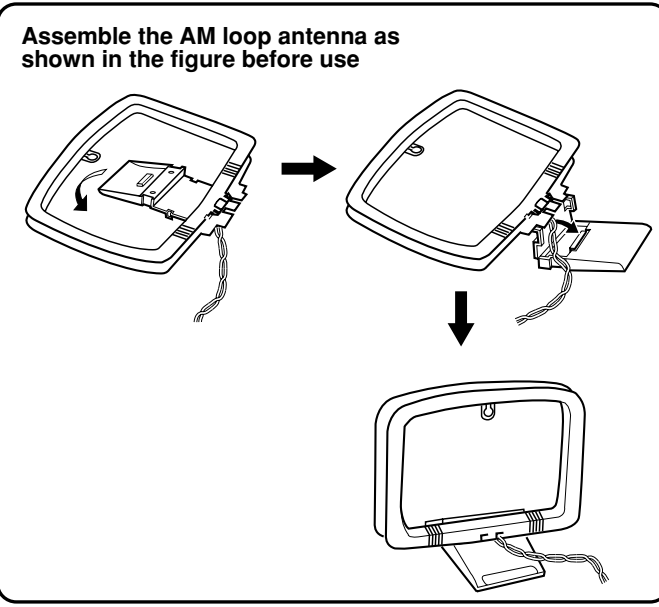
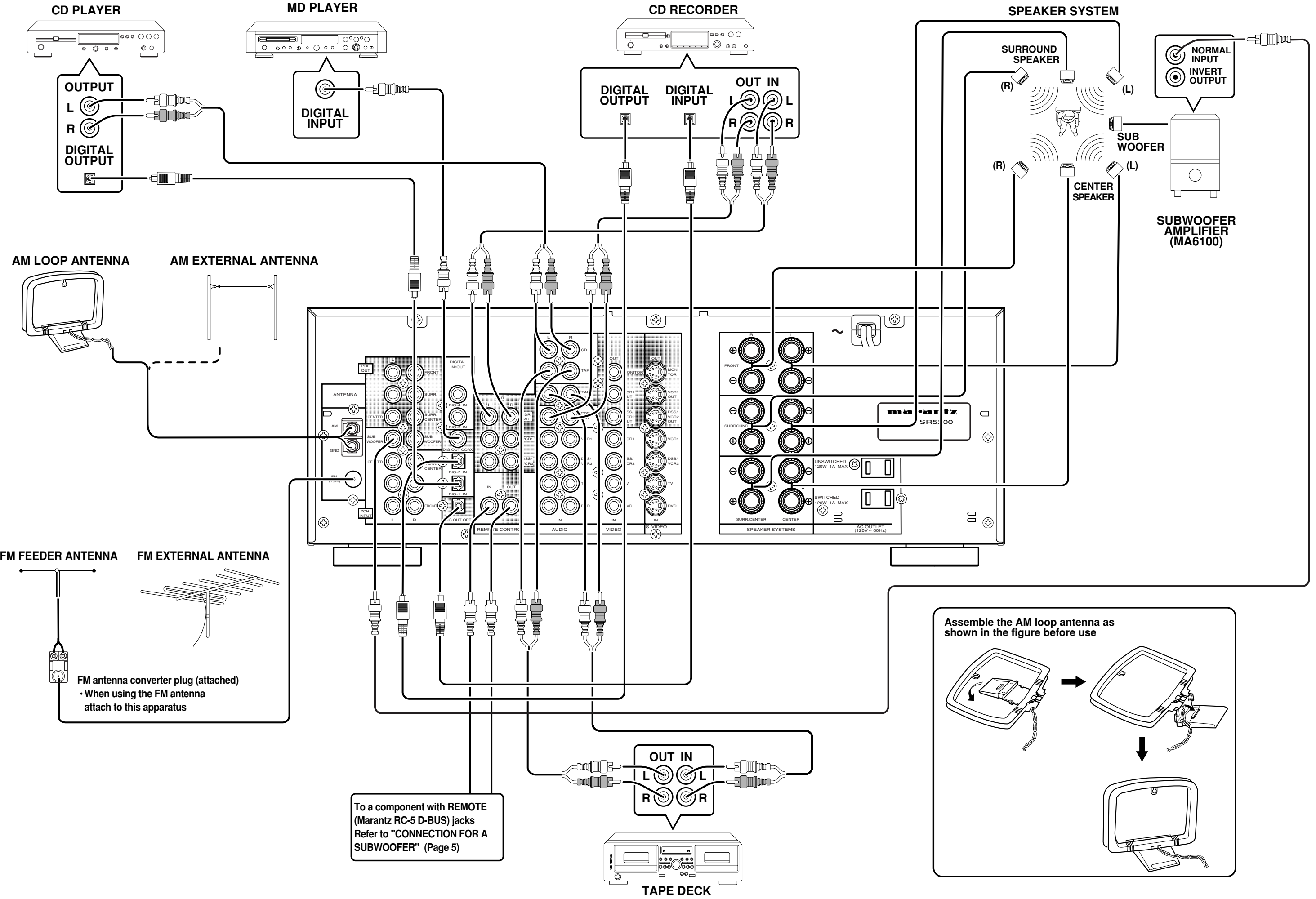

To a component with REMOTE (Marantz RC-5 D-BUS) jacks  
Refer to "CONNECTION FOR A SUBWOOFER" (Page 5)



# TABLE OF CONTENTS

<b>INTRODUCTION</b> .....	<b>2</b>
<b>DESCRIPTION</b> .....	<b>2</b>
<b>FEATURES</b> .....	<b>2</b>
<b>FRONT PANEL FEATURES</b> .....	<b>3</b>
<b>REAR PANEL CONNECTIONS</b> .....	<b>4</b>
<b>REMOTE CONTROL OPERATION</b> .....	<b>6</b>
OPERATION .....	6
FUNCTION AND OPERATION .....	6
PROGRAMMING THE REMOTE CONTROLLER .....	7
OPERATION OF REMOTE CONTROL UNIT .....	8
<b>SET-UP</b> .....	<b>9</b>
ON SCREEN DISPLAY MENU SYSTEM .....	9
OSD MAIN MENU .....	10
SYSTEM SETUP .....	10
SPEAKERS SETUP .....	11
SURROUND MODE .....	12
CHANNEL LEVEL CONTROL .....	12
<b>BASIC OPERATION</b> .....	<b>13</b>
LISTENING TO THE TUNER .....	13
PLAYBACK OPERATION .....	14
TV AUTO ON/OFF FUNCTION .....	14
SETTING THE SLEEP TIMER .....	15
<b>ON SCREEN DISPLAY INFORMATION</b> .....	<b>15</b>
<b>SURROUND MODES</b> .....	<b>17</b>
<b>TROUBLE SHOOTING</b> .....	<b>19</b>



## INTRODUCTION

Thank you for purchasing the Marantz SR5200 DTS/Dolby Digital Surround receiver.

This remarkable component has been engineered to provide you with many years of home theater enjoyment.

Please take a few minutes to read this manual thoroughly before you connect and operate the SR5200.

As there are a number of connection and configurations options, you are encouraged to discuss your own particular home theater setup with your Marantz A/V specialist dealer.

## DESCRIPTION



DTS was introduced in 1994 to provide 5.1 channels of discrete digital audio into home theater systems.

DTS brings you premium quality, discrete multi-channel digital sound to both movies and music.

DTS is a multi-channel sound system designed to create full range digital sound reproduction.

The no compromise DTS digital process sets the standard of quality for cinema sound by delivering an exact copy of the studio master recordings to neighborhood and home theaters.

Now, every moviegoer can hear the sound exactly as the moviemaker intended.

DTS can be enjoyed in the home for either movies or music on DVD's, LD's, and CD's.



Dolby Digital lets you enjoy Digital TV, Digital Satellite as well as DVD, LD software in digital surround, which is the next step above Dolby Pro Logic. In Comparison with Dolby Pro Logic, Dolby Digital can provide separate left surround and right surround channels, for more precise localization of sound and a more convincing, realistic ambience.

And, with Dolby Digital all five main channels can be full ranged and a subwoofer can be added to each channel, if desired.

By providing up to 5.1 channels of digital audio independently. Dolby Digital lets you enjoy better sound quality and more powerful presence than conventional Dolby Surround.

Pro Logic II, the next generation in Dolby Surround Pro Logic technology, brings the excitement of surround sound to any existing stereo mix, while making existing Dolby Surround mixes sound more like discrete 5.1-channel surround sound. It works with CDs, VHS tapes and TV shows, and MP3 files and radio broadcasts-converting all of these source to surround sound, without the artifacts by other matrix-decoding technologies.

"Dolby", "Pro Logic", and the double-D symbol are trademarks of Dolby Laboratories. Confidential unpublished works.

"DTS", "ES" and "DTS Digital Surround" are trademarks of Digital Theater Systems, Inc.

## FEATURES

- Dolby Digital and DTS surround sound decoding, plus Dolby Pro LogicII decoding and a variety of additional surround modes.
- 6.1 mode reproduces the original 6.1 channel soundfield by extracting the surround back signal from surround left and surround right channels.
- 96 kHz/ 24 bit decoding for highest possible fidelity and bandwidth, and high-resolution playback of 96 kHz/ 24 bit PCM audio sources.
- 90 watts to each of the six main channels; the power amp section features advanced, premium high-storage power supply capacitors, and fully discrete output stages housed in cast aluminum heat sinks.
- 6.1 channel pre-amp outputs for connection to external components such as a subwoofer and external power amplifiers.
- Seven-channel direct inputs accommodate future surround sound formats or an external digital decoder.
- 4 Digital inputs, for connection to other sources, such as DVD, DSS, CD, CD-R or MD.
- 2 Digital outputs for connection to CD-R or MD.
- High-quality AM /FM tuner with 30 station presets.
- Source Direct switch bypasses, tone controls and bass management for purest audio quality.
- S-video and composite video switching .
- On- Screen- Display with both Composite and "S" video.
- Front panel A/V inputs, with S-video .
- Easy to use, on-screen menu.

# FRONT PANEL FEATURES (SEE PAGE iii.)

## ① POWER switch and STANDBY indicator

When this switch is pressed once, the unit turns ON and display appears on the display panel. When pressed again, the unit turns OFF and the STANDBY indicator lights.

When this unit is in the standby mode, pressing one of the **FUNCTION SELECTOR** buttons also allows to turn the power on.

"When the STANDBY indicator lights up, the apparatus is NOT disconnected from the AC supply mains."

## ② PHONES jack for stereo headphones

Conventional dynamic headphones can be plugged in here.

### Notes:

When using headphones, the surround mode is switched automatically to STEREO and the sound from the speakers is muted.

The surround mode returns to the previous setting as soon as the plug is removed from the jack.

## ③ SURROUND MODE Selector knob

When this knob is turned, the surround mode is switched in the following sequence.

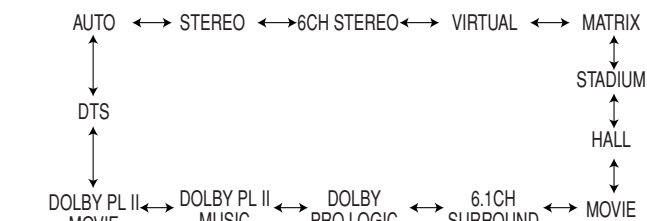

**Note:**  
Not all modes will be present if an analog input is selected.

## ④ VOLUME control knob

Adjusts the overall sound level. Turning the control clockwise increases the sound level.

## ⑤ FUNCTION SELECTOR buttons (AUDIO/VIDEO)

These buttons are used to select the sources. The video function selector, such as TV, DVD, VCR1 and DSS/VCR2, and AUX, selects video and audio simultaneously. Audio function sources such as CD, TAPE, CDR/MD, and TUNER may be selected in conjunction with a Video source. This feature (Sound Injection) combines a sound from one source with a picture from another. Choose the video source first, and then choose a different audio source to activate this function.

## ⑥ 7CH INPUT button

Press this button to select the output of an external multi channel decoder.

## ⑦ A/D (Analog/Digital) SELECTOR button

This is used to select between the analog and digital inputs.

### Note:

This button is not used for an input source that is not connected to a digital input.

## ⑧ S. ( Source) DIRECT button

When this button is pressed, the tone control circuit is bypassed as well as Bass Management.

### Notes:

The surround mode is automatically switched to AUTO when the source direct function is turned on.

Additionally, Speaker Configurations are fixed automatically as follow.

Front SPKR = Large

Center SPKR = Large

Surround SPKR = Large

Surround Center SPKR = Yes

Sub woofer = Yes

## ⑨ SLEEP button

Set the sleep timer function with this button .

## ⑩ DIMMER button

When this button is pressed once, the display is dimmed.

When this button is pressed twice, the display is turned off and "DISPLAY OFF" indicator lights up.

Press this button again to turn the display ON again.

## ⑪ MUTE button

Press this button to mute the output to the speakers. Press it again to return to the previous volume level.

## ⑫ CLEAR button

Press this button to cancel the station memory setting mode or preset scan tuning.

## ⑬ MEMORY button

Press this button to enter the tuner preset memory numbers and station names.

## ⑭ TUNING / PRESET UP and DOWN buttons

During reception of AM or FM, you can scan the other frequencies or select another preset station pressing these buttons.

## ⑮ FREQUENCY / PRESET button

During reception of AM or FM, you can change the function of the UP/DOWN buttons for scanning frequencies or selecting preset stations by pressing this button.

## ⑯ FM MODE button

Press this button to select the auto stereo mode or mono mode when the FM band is selected. The AUTO indicator lights in the auto stereo mode.

## ⑰ INFRARED SENSOR window

This window receives infrared signals from the remote control unit.

## ⑱ AUX input jacks

These auxiliary video/audio input jacks accept the connection of a camcorder, portable VCR, etc.

## REAR PANEL CONNECTIONS (SEE PAGE iii.)

All connections to the rear panel should be made with the entire system powered off.

To avoid errors, it is advisable to connect one cable at a time between the various components.

### (1) FM antenna terminal (75 ohms)

Connect an external FM antenna with a coaxial cable, or a cable network FM source.

#### AM antenna and ground terminals

Connect the supplied AM loop antenna. Use the terminals marked "AM" and "GND".

The supplied AM loop antenna will provide good AM reception in most areas.

Position the loop antenna until you hear the best reception.

### (2) PRE OUT jacks

Jacks for Front - L/R, Center, Surround and Surround center. Use these jacks for connection to an external power amplifier.

### (3) SUB WOOFER output jack

Connect to the input jack(s) of the power amplifier for subwoofer channel or powered subwoofer.

### (4) Analog audio outputs for audio source equipment

#### TAPE and CD-R/MD

Connect each output to the audio inputs (REC in) of your recording equipment.

### (5) Analog audio inputs

#### CD, TAPE, and CD-R/MD

Connect the audio outputs of your source components to the input jacks on the receiver.

### (6) Video outputs

#### VCR1, and DSS/VCR2

Connect each output to the video input (REC in) of your video recording equipment.

### (7) TV MONI. (VIDEO/S-VIDEO) output jacks

Connect the TV MONI jack to your TV's video input (VIDEO IN) jack. You can connect your video equipment with S-VIDEO jacks if possible, or the composite VIDEO jacks.

You must use the same type of connection from your video player into the receiver, and out of the receiver into your TV.

Both must be composite video or both must be S-Video. You cannot convert a signal from one type to the other.

When you connect to S-video connections, there will be no signal output from the composite video jacks.

### (8) SPEAKER SYSTEMS terminals

#### FRONT Left & Right speakers output terminals

Connect to the front left & right speakers.

#### CENTER speaker output terminals

Connect to the center speaker.

#### SURROUND Left & Right speakers output terminals

Connect to the surround (rear) left & right speakers.

#### SURROUND Center speakers output terminals

Connect to the surround center speakers.

### (9) 7 CH INPUT jacks

Connect to the outputs of an external multichannel decoder.

### (10) DIGITAL outputs

#### Optical and Coaxial

Connect digital input of your digital recording equipment.

### (11) DIGITAL inputs

#### Fig.1,2 (Optical) and Fig. 3, 4 (Coaxial)

Connect each input to the digital output of your source equipment. Use the system setup menu to assign digital input to appropriate source. (see page. 10)

#### Note :

The coaxial connections are not for AC-3 RF from the LD player, If you want to decode this type of signal, an external demodulator must be used.

### (12) REMOTE CONT. IN/OUT terminals

Connect to a Marantz component equipped with remote control (RC-5) terminals.

### (13) Analog audio outputs for video source equipment

#### VCR1, and DSS/VCR2

Connect each output to the audio inputs (REC in) of your video recording equipment.

### (14) Analog audio inputs for video source equipment

#### TV, DVD, VCR1, and DSS/VCR2

Connect each input to the audio outputs of your video source equipment.

### (15) Video inputs

#### Ex: TV, DVD, VCR1, and DSS/VCR2

Connect each input to the video outputs of your video source equipment.

### (16) S-video inputs

#### Ex: TV, DVD, VCR1, and DSS/VCR2

Connect each input to the S-video outputs of your video source equipment.

### (17) AC OUTLET

Connect the power cables of components such as a DVD and CD player to these outlets. Both SWITCHED and UNSWITCHED outlets are provided.

The one marked SWITCHED provides power only when the SR5200 is turned on and is useful for components which you use every time you play your system.

The one marked UNSWITCHED is always live as long as the SR5200 is plugged into a live outlet.

A component connected here may be left on permanently, or may be switched off with its own power switch.

#### Caution:

In order to avoid potential turn-off thumps, anything plugged in here should be powered up BEFORE the SR5200 is turned on.

### (18) Power cable

Connect to AC power outlet.

SR5200 can be powered by 120V AC only.

### REMOTE CONTROL BUS CONNECTIONS

This unit is equipped with a remote control function. By connecting this unit's remote control jacks to a Marantz CD player or tape deck equipped with remote control (RC-5) jacks, it allows system remote control to operate. Connect **REMOTE CONTROL OUT** jack of SR5200 to **REMOTE CONT. IN** of other Marantz equipment, i.e. CD player or tape deck, by using an RCA pin cable.

**Note:**  
If a component equipped with remote control (RC-5) jacks has an INT/EXT switch on the rear panel, set the switch to EXT when using the system control function.

**(Connection example)**

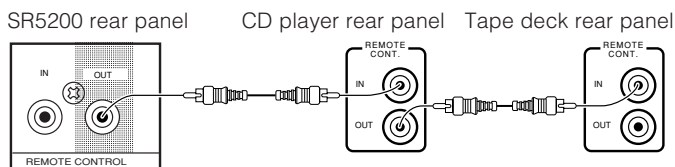

### CONNECTION FOR A SUBWOOFER

Use this connection when using a sub-woofer speaker. You can also connect a powered subwoofer.

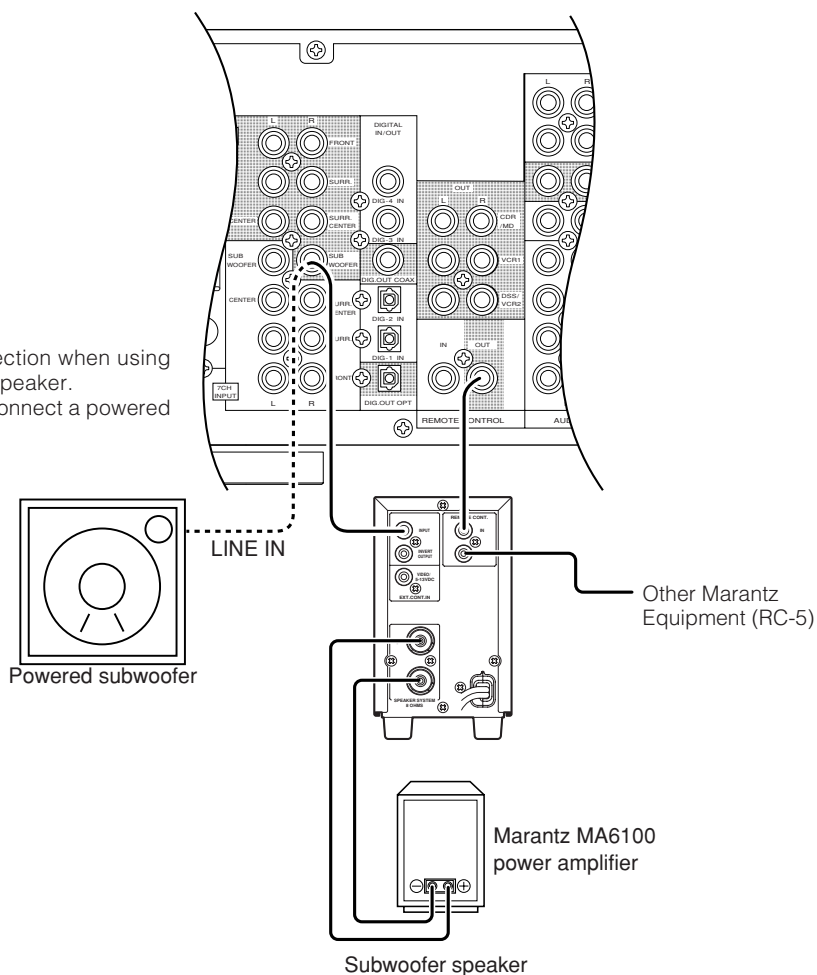

**Controlling the power ON/OFF of a power amplifier connected to the SR5200 through Marantz remote control**

1. Now the MA6100 can be turned ON / OFF in synchronism with the power ON / OFF of the SR5200.

**Notes:**

- Be sure to connect the remote control bus before the procedure above.

# REMOTE CONTROL OPERATION

## OPERATION

The provided remote control unit is a universal remote controller. The **POWER** button [2], numeric buttons [9] and control buttons [12] are used in common across different input source components.

The input source controlled with the remote control unit changes when one of the input selector buttons [3] is pressed.

• Example: To select the DVD as the input source and play the DVD player.

Press the **DVD** button [3] twice within 2 seconds.

The input selector of the SR5200 is switched to DVD and the remote control unit is set for control of the DVD player. Press the **PLAY** button on the remote controller .

## FUNCTION AND OPERATION

### 1 Transmitting indicator

Lights up during a button is pressed and an infrared signal is sending.

### 2 Main POWER buttons

Press to switch the power of the SR5200 ON or OFF after pressing the **AMP** button [3].

### 3 Input selector buttons/ FUNCTION SELECTOR buttons (AUDIO/VIDEO INPUT)

Press one of these buttons once or twice to select a particular source component. For example, to set the receiver to the DVD input, press the **DVD** button twice within 2 seconds.

#### Note:

**CDR/MD** button is set CDR function at initial. To switch MD function, press and hold down **CDR/MD** button and press **2** button [9].

To return CDR function, press and hold down **CDR/MD** button and press **1** button [9].

### 4 MAIN VOLUME UP (▲) /DOWN (▼) buttons

Main volume control of the SR5200. The front, surround, center and subwoofer channel volumes controlled by these buttons simultaneously.

### 5 MUTE button

Muting button of the SR5200. Press this button decrease the sound temporarily . Press this button again to return to the previous sound.

### 6 MENU button

This button is used to enter the OSD main menu.

### 7 Cursor buttons (◀, ▶, ▲, ▼, OK)

Use these button when operating the setup menu. See page 10.

### 8 MENU OFF button

This button is used to exit from the setup menu.

### 9 Numeric buttons 1 to 9 (A, B, C ... Z, -) / Surround mode buttons

#### Numeric buttons

These buttons are used to enter figures in the selection of a tuner preset station and station name preset or to set select a CD track number, etc. The functions of these buttons are dependent on the function button selected.

#### Surround mode buttons (when AMP mode is selected)

These buttons are used to select the surround mode.

#### Note:

The **CS5.1** button is unavailable for SR5200.

### 10 P.SCAN (preset scan) button (when TUNER mode is selected)

This button is used to start preset scan when SR5200 is selected TUNER mode.

### 11 0 / A/D button

#### 0 button

This button is used to enter the number "0"

#### A/D button (when AMP mode is selected)

This is used to switch between the analog and digital inputs.

### 12 CONTROL buttons

These buttons are used when operating the CD player, TAPE deck, etc. The function of these buttons are dependent on the function button selected.

For the controllable functions of each input function, please refer to following table.

	TV	VCR	DVD	DSS	TUNER	CD	TAPE	CDR	MD
◀ CHANNEL/SKIP	CH-	PREV	PREV	CH-	CH-	PREV	PREV	PREV	PREV
▶ CHANNEL/SKIP	CH+	NEXT	NEXT	CH+	CH+	NEXT	NEXT	NEXT	NEXT
◀ TUNE/SERCH	—	REWIND	REWIND	—	TUNING-	REWIND	REWIND	REWIND	REWIND
▶ TUNE/SERCH	—	FF	FF	—	TUNING+	FF	FF	FF	FF
●	—	REC	—	—	—	—	REC	REC	REC
▶ MODE	—	—	—	—	MODE	—	DIRECTION	—	—
DSIP/RDS	CH DISPLAY	PAUSE	PAUSE	CH DISPLAY	—	PAUSE	PAUSE	PAUSE	PAUSE
▶ F.DIRECT	—	PLAY	PLAY	—	FREQ. DIRECT	PLAY	PLAY	PLAY	PLAY
+/A/ANT	VIDEO	TV/VCR	DISC +	DSS/VCR	—	DISC +	DECK A	—	—
-/B/VCR	VIDEO	TV/VCR	DISC -	DSS/VCR	—	DISC -	DECK B	—	—
■ PTY	—	STOP	STOP	—	—	STOP	STOP	STOP	STOP

### 13 ATT (attenuater) button

When the input signal is too high and the voice distorts even by throttling the SR5200 VOLUME control, turn on this function. "ATT" is indicated when this function is activated.

The input level is reduced. Attenuater is invalid for use with the output signal of "REC OUT".

### 14 TREBLE buttons

These buttons are used to adjust the tone control of high frequency sound for left, center and right speaker.

### 15 BASS buttons

These buttons are used to adjust the tone control of low frequency sound for left, center right and subwoofer speaker.

### 16 MEMO button

Memory enable button for various preset functions.

**17 CLEAR button**

This button is used to cancel for certain memory or programming operations.

**18 DIMMER button**

When this button is pressed once, the display is dimmed.  
When this button is pressed twice, the display is turned off and the "DISPLAY OFF" indicator lights up.  
Press this button again to turn on the display again.

**19 NIGHT button**

Pressing this button prevents the Dolby Digital signal from playback at a loud voice. This function reduces the voice by 1/3 to 1/4 at maximum. Thus, it eliminates the occurrence of an abruptly loud voice at night. However, the function is valid only for the case when the Dolby Digital signal is entered into OPTICAL or COAXIAL and data to compress the voice exists in the signal to be played back.

**20 S- ( Source) DIRECT button**

When this button is pressed, the tone control circuit is bypassed as well as Bass Management.

**21 SETUP / T.TONE button**

Test tone function is used for adjusting the balance between the volume levels of speaker channels. Press AMP button and press this button to enter the test tone mode.

**22 OSD button**

When this button is pressed, the current setting are displayed on the TV monitor.

**23 SLEEP (sleep timer) button**

This button is used for setting the sleep timer. It can be operated the same way as the button in unit.

**24 TV VOLUME UP (▲) /DOWN (▼) buttons**

These buttons increase or decrease TV's volume.

**PROGRAMMING THE REMOTE CONTROLLER**

The remote controller RC5200SR must be programmed to use the codes for your appliances of different brands. This is done by keying in a 4-digit code or by scanning the codes until the correct one is found. We recommend to using the 4-digit code. This mode is faster and more reliable. The code scanning method should be used only if you cannot find the code for one of your appliances. The codes are listed at the end of this book.

**Important:**

Use the remote control buttons for programming, not the buttons of the receiver or other appliances.

**PROGRAMMING WITH THE 4-DIGIT CODE**

1. Press and hold down the function button [3] for the appliance which should be controlled and press **SETUP** [21] until the indicator [1] blinks twice.
2. Press the 4-digit code for appliance (codetable at the end of this book)
3. When the procedure is successful, the indicator will blink twice.

**Notes:**

If the indicator did not blink twice, then repeat steps 1 through 2 and try entering the same code again.

**SCANNING THE CODE TABLE**

1. Switch on the appliance which should be controlled.
2. Press and hold down the function button [3] for appliance which should be controlled and press **SETUP** [21] until the indicator [1] blinking twice.
3. Press the code **9 - 9 - 1**.  
The indicator will blink twice.
4. Aim the remote control at the appliance and slowly alternate between pressing **POWER** [2] and the function button [3] for the appliance.
5. Stop when the appliance turns off.
6. Press **SETUP** [21] once to lock in the code.

**CHECKING THE CODE**

1. Press and hold down the function button [3] for appliance which should be controlled and press **SETUP** [21] until the indicator [1] blinking twice.
2. Press the code **9 - 9 - 0**.  
The indicator will blink twice.
3. To view the code for first digit, press **1** once.  
Wait 3 seconds, count the indicator blinks (e.g. 3 blinks = 3) and write down the number.  
**Note:**  
If a code digit is "0", the indicator will not blink.
4. Repeat step 3 three more times for remaining digits. Use **2** for the second digit, **3** for the third digit, and **4** for the fourth digit.



Once you have found and the codes for your various appliances, you may want to write them down here.

- TV \_\_\_\_\_
- VCR \_\_\_\_\_
- DSS \_\_\_\_\_
- DVD \_\_\_\_\_
- CD \_\_\_\_\_
- TAPE \_\_\_\_\_
- CDR \_\_\_\_\_
- MD \_\_\_\_\_

## OPERATION OF REMOTE CONTROL UNIT

### 1. Remote control

The distance between the transmitter of the remote control unit and the IR SENSOR of the SR5200 should be less than about 5 meters. If the transmitter is pointed to a direction other than the IR SENSOR or if there is an obstacle between them, remote control may not be possible.

#### Remote-controllable range

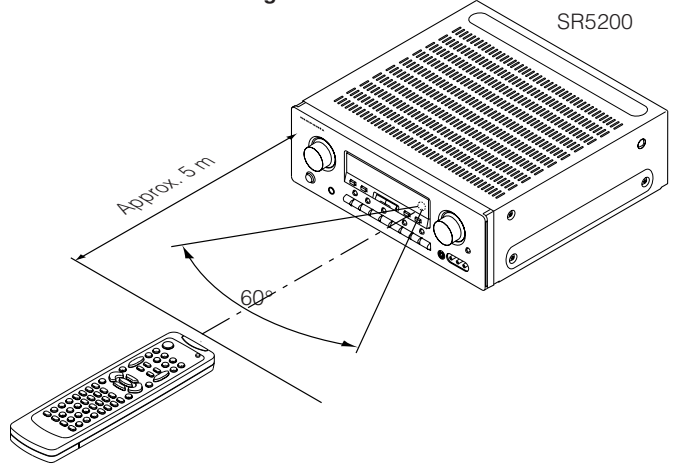

Remote control unit (RC5200SR)

### 2. Loading batteries

The life of the batteries used with the remote control unit is about 4 months with normal use. Also be sure to replace batteries earlier when you notice that they are getting weak.

#### (1) Remove the back cover.

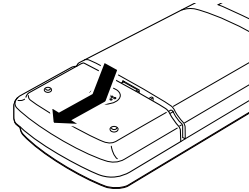

#### (2) Insert the new batteries (AAA type) with correct (+) and (-) polarity.

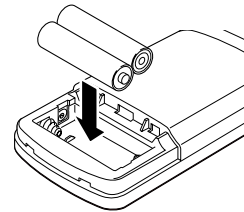

#### (3) Close until it clicks.

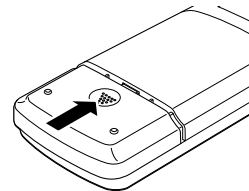

# SET-UP

After all components are connected, initial setup must be performed.

## ON SCREEN DISPLAY MENU SYSTEM

The SR5200 incorporates an on-screen menu system, which makes various operations possible by using the cursor (◀, ▶, ▲, ▼) and OK buttons on the remote controller.

The settings made with these buttons are also shown in the on-screen display.

### OSD MAIN MENU

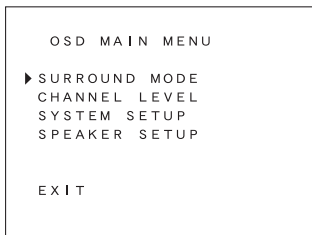

### SURROUND MODE

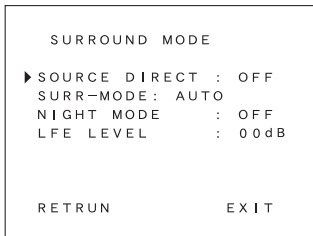

### SYSTEM SETUP 1/2

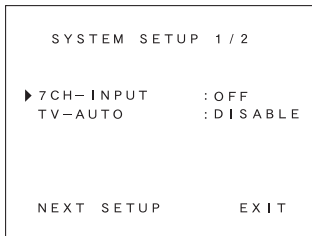

### SPEAKER SETUP 1/3 SPKR SIZE

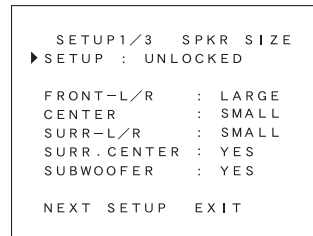

### CH. LEVEL CONTROL

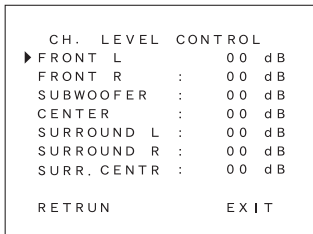

### SYSTEM SETUP 2/2

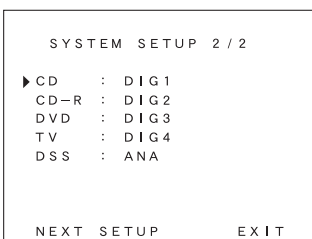

### SPEAKER SETUP 2/3 SPKR DISTANCE

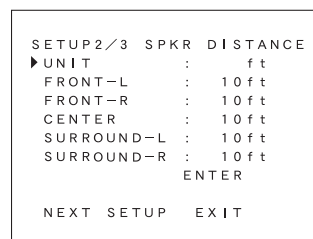

### SPEAKER SETUP 3/3 SPKR LEVEL

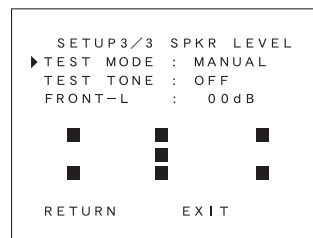



## OSD MAIN MENU

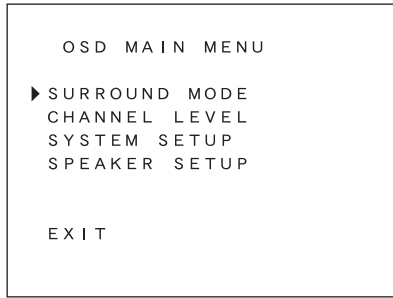

1. Press the **AMP** button [3].
2. Press the **MENU** button [6] to display the "MAIN MENU" of the on-screen display menu.  
Choose a desired item in the contents with ▲ or ▼ button, and press the **OK** button to select.  
Display will change to menu for each item.

## SYSTEM SETUP

### SYSTEM SETUP 1/2

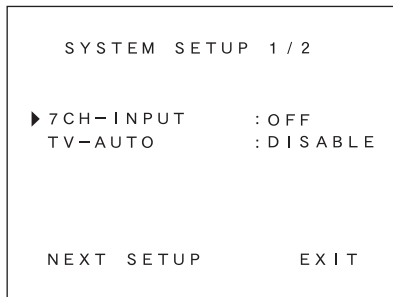

**7CH-INPUT** : The 7 channel input of the SR5200 can be selected to use a 7channel input. Select 7 channel use by ◀ or ▶ button.

**TV AUTO** : This product is equipped with a TV-auto ON/OFF system, which automatically turns on or off the power 1 second to 5 minutes after the TV video input signal has been sent or has been stopped.  
Switch the TV AUTO ON/OFF function to enable or disable with < or > button.  
To use this function, connect the TV video input to TV tuner's video output.

**NEXT SETUP/EXIT** :If you desire to continue the next setup ,press the **OK** button on NEXT-SETUP, if you desire to exit from OSD menu system, press the **OK** button on EXIT or press the **MENU OFF** button [8].

### SYSTEM SETUP 2/2 (SELECTING THE DIGITAL INPUT)

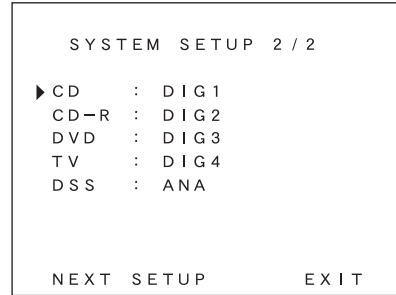

Four digital inputs can be assigned for the desired source. Use this menu to determine which source is connected to which input.

#### Example;

When the digital output of a DVD player is connected to Digital 4 (input jack) of the SR5200;

1. Move the cursor on the line of the DVD with cursor buttons ▲ or ▼.
2. Press the the cursor ◀ or ▶ button until until "DIG4" is displayed.
3. Press the **OK** button to chose.
4. If you desire to continue the next setup, press the **OK** button on NEXT-SETUP.

If you desire to exit from OSD menu system, press the **OK** button on EXIT or press the **MENU OFF** button [8].

#### Notes:

The TUNER, TAPE, VCR1 and AUX are assigned to the analog input, and are prevented from selecting any digital input. While the DTS-LD or DTS-CD is playing, this setup is not available, this is to avoid noise being generated from the analog input. Stop the LD or CD playback to setup.  
The SR5200 does not switch from digital input to analog input or vice versa automatically.  
In the event that both digital and analog inputs are connected to SR5200, if you desire to switch to an analog input temporarily, you can switch by pressing the **A/D** button [7].

## SPEAKERS SETUP

The home theater system you already have installed should function provided that there are left, center and right front speakers, left and right rear/surround speakers and a subwoofer. For best results we recommend that all front speakers be of the same type, with identical or similar driver units. This will deliver smooth pans across the front sound stage as the action moves from side to side.

Your center channel speaker is very important as over 80 % of the dialog from a typical motion picture emanates from the center channel. It should possess similar sonic characteristics to the main speakers.

Surround channel speakers need not be identical to the front channel speakers, but they should be of high quality.

The surround center speaker is useful for playback of Dolby Digital Surround EX or DTS-ES. One of the benefits of both Dolby Digital (AC-3) and DTS is that surround channels are discrete full range, while they were frequency limited in earlier "Pro Logic" type systems. Bass effects are an important part of home theater. For optimal enjoyment a subwoofer should be used as it is optimized for low frequency reproduction. If you have full range front speakers, however, they may be used in place of a subwoofer with proper setting of the switches in the menu system.

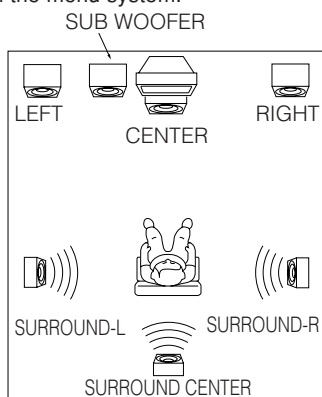

If possible, mount the surround speakers on the walls to the sides of the viewing area, 2-3 feet above seated viewers, firing straight across at each other.

### SPKR SETUP 1/3 (SPKR SIZE)

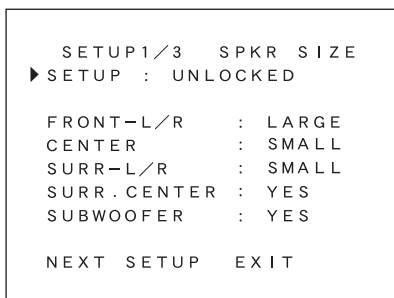

**SETUP:** Select "LOCKED" with ◀ or ▶ button in order to lock the contents of the SPCR SET UP MENU.

When you want to change the contents of this setup, select "UNLOCKED".

#### SPKR SIZE

This menu enters the information about which type of speakers will be used for each channel.

In turn, these settings will determine which speakers receive low frequency information.

For the purpose of establishing proper bass reproduction, use the LARGE settings if the speaker being used at any position is a traditional full-range loudspeaker that is capable of reproducing sound below 100 Hz and you are not using a subwoofer.

Use the SMALL setting for smaller, frequency-limited speakers that are not able to reproduce sounds below 100Hz and you are using a subwoofer. Low frequencies will be diverted from the speaker to the subwoofer.

Note that when "small" speakers are used it is advisable to install a separate subwoofer, especially if you wish to appreciate the full impact of a good home theater soundtrack.

If the Surround speakers or Center speaker will not be used, set NONE for each speaker. The NONE setting will send the audio for the channel to other speakers.

**FRONT -L/R :** Select the type of front speakers with ◀ or ▶ button.

**CENTER :** Select the type of center speaker with ◀ or ▶ button.

**SURR-L/R :** Select the type of surround speakers with ◀ or ▶ button.

**SURR.CENTER :** Select the surround center speaker YES or NO with ◀ or ▶ button.

**SUBWOOFER:** Select the subwoofer speaker YES or NO with ◀ or ▶ button.

#### Notes:

The SUBWOOFER cannot be set to NO when the front speakers are set to SMALL.

This speaker size setup is not effective when the SOURCE-DIRECT or 7CH. Input is selected.

### SPKR SETUP 2/3 (SPKR DISTANCE)

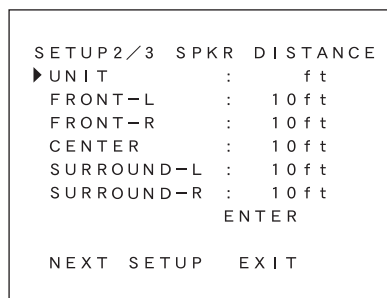

Use this parameter to specify the distance of the speaker's position from the listener.

The delay time is automatically set according to these distances.

**UNITS:** You can select Meters or Feet.

If you select "ft", the setting parameter will change in 1 foot steps.

If you select "m", it will change in 0.3 meter steps.

Select speaker with ▲ or ▼ button, and input each speaker's distance with ◀ or ▶ button.

When the input for each speaker's distance has been finished, move the cursor to ENTER and press the OK button.

#### NOTES :

If your selection(s) are out of range, the distance cannot be stored. Placement beyond that distance is beyond the range of the automatic time delay feature.

The delay feature does not function in the SOURCE-DIRECT ,7 CH-Input modes and decoding of 96 kHz sources.

### SPKR SETUP 3/3 (SPKR LEVEL)

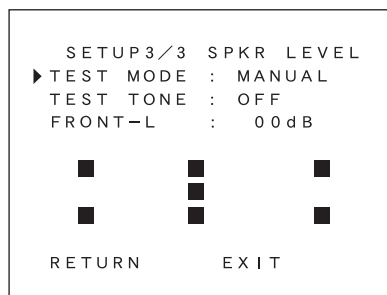

#### SPKR LEVEL

**TEST MODE:** Selects the mode for generating the test tone.

If you select AUTO, the test tone will be cycled through in a circular pattern which is Left → Center → Right → Surround Right → Surround Center → Surround Left → Subwoofer → Left → ... 3 seconds for each channel.

If you select MANUAL, press the OK button to select the test tone channels after the "TEST TONE ON".

**TEST TONE:** Press the ◀ or ▶ button, ON is indicated and the test tone starts from the front L-CH speaker.

Press the ◀ or ▶ button again on this item. OFF is indicated and the output of the test tone will stop.

**Channel:** Adjust the level of test tone for each channel with the ◀ or ▶ buttons of the RC5200SR. The current volume level is shown at the center of the display.

## SURROUND MODE

SURROUND MODE	
▶ SOURCE DIRECT	: OFF
SURR-MODE	: AUTO
NIGHT MODE	: OFF
LFE LEVEL	: 00 dB
RETRUN	EXIT

**SOURCE DIRECT** : Switch the source direct ON or OFF with ◀ or ▶ button. This bypasses the surround processing and crossover for the main speakers (front left and right will be full range and the subwoofer will be ON)

**Note:** Surround mode cannot be changed in Source Direct mode.

**SURR-MODE** : Select the surround mode with ◀ or ▶ button.

**NIGHT MODE** : Switch the NIGHT MODE ON or OFF with ◀ or ▶ button.

Selecting the Night Mode ON is effective in Dolby Digital only, and it compresses the dynamic range.

This softens loud passages such as sudden explosions, to help prevent disturbing others late at night.

**LFE LEVEL** : Select the output level of the LFE signal included in the Dolby Digital signal or the DTS signal. Select 0dB, -10 dB or OFF with ◀ or ▶ button.

The level is ordinarily set to 0 dB. When use DTS music source, LFE level is set to -10 dB.

## CHANNEL LEVEL CONTROL

CH. LEVEL CONTROL	
▶ FRONT L	: 00 dB
FRONT R	: 00 dB
SUBWOOFER	: 00 dB
CENTER	: 00 dB
SURROUND L	: 00 dB
SURROUND R	: 00 dB
SURR. CENTR	: 00 dB
RETRUN	EXIT

Desired channels can be selected by pressing ▲ or ▼ button.

Each channel level will be adjusted by pressing ◀ or ▶ button.

Only the usable channels which are determined depending on the SURROUND mode, and SPEAKER SETTING are displayed.

# BASIC OPERATION

## LISTENING TO THE TUNER

### MANUAL TUNING

1. To select the tuner as the source, press the **TUNER** button ⑤ on the front panel or press the **TUNER** button ③ on the remote.
2. Press the **TUNER** button ⑤ on the front panel or press the **TUNER** button ③ on the remote to select the desired frequency band if required.
3. Press the **F/P** button ⑮ on the front panel to display the frequency.
4. Press the **TUNING/PRESET ▲** or **▼** button ⑭ on the front panel or press the **◀◀** or **▶▶** button ⑫ on the remote.
5. If FM is selected, press the **MODE** button ⑯ on the front panel or press the **MODE** button ⑫ on the remote control to select the desired audio mode.

### (FM) MODE BUTTON OPERATION

When "AUTO" indicator is on in the display, FM stations that broadcast in stereo will be received in stereo and the "STEREO" indicator lights.

When "AUTO" indicator is off, all the FM stations will be received in mono regardless of whether or not they are broadcasting in stereo.

### AUTO TUNING (USING THE SR5200)

1. Press the **F/P** button ⑮ on the front panel to display the frequency.
2. Press the **TUNING/PRESET ▲** or **▼** button ⑭ on the front panel for more than 1 second to start the Auto tuning function.

### AUTO TUNING (USING THE REMOTE CONTROL UNIT)

Press **◀◀** or **▶▶** button ⑫ for more than 1 second to start the Auto tuning function.

### PRESET TUNING

With this unit you can preset up to 30 FM/AM stations in any order. For each station, you can memorize the frequency and reception mode if desired.

#### 1-a. Manual Presetting (Using the SR5200)

1. Refer to the "MANUAL TUNING" or "AUTO TUNING" section above to tune in a desired station.
2. Press the **MEMORY** button ⑬. "MEMORY" indicator starts blinking on the display.  
While "MEMORY" is still blinking (approx. 5 seconds), select the preset number by pressing the **TUNING/PRESET ▲** or **▼** button ⑭ then press the **MEMORY** button ⑬ again.
3. When a number has been properly input, "MEMORY" indicator stops blinking and goes out.  
The station is now stored in the specified preset memory location.

#### 1-b. Manual Presetting (Using the remote control unit)

1. Tune in a desired station.
2. Press the **MEMO** button ⑯.
3. Enter the desired preset number with ten keypad ⑨.
4. Then, press **MEMO** button ⑯ again to store.

#### 2. Auto Presetting

This function automatically scans the AM and FM band and enters all stations with sufficient signal strength into the memory.

1. Press and hold down the **MEMORY** button ⑬ and **TUNER** button ⑤ simultaneously, auto presetting will start.
2. "MEMORY" will blink on the display.
3. Each time the tuner finds a station, the scanning will pause and memory. Auto presetting will starts.
4. Operation stops automatically when all 30 preset memory positions are filled or when auto scanning attains the highest end of all bands.  
To stop the auto preset function at anytime, press the **CLEAR** button ⑰.

### 3. Recalling a Preset Station

1. Press the **F/P** button ⑮ to change the display to preset.
2. Select the desired preset station by pressing **TUNING/PRESET ▲** or **▼** button ⑭ on the front panel or press **CHANNEL** button ⑫ on the remote.

#### Note:

To directly access the preset stations using the numeric keypad, select the desired preset station by entering one or two digits using the numeric keypad ⑨.

To return to the Manual Tuning mode, press the **F/P** button ⑮.

### 4. Preset Scan Tuning (Using the remote control unit)

1. Press the **P.SCAN** button ⑩ on the remote control. (The preset station with the smallest preset number is recalled first. If no stations have been preset, "NO PRESET" shows in the display and the unit returns to the previous mode.)
2. Preset stations are recalled in sequence (CH-1 → CH-2, etc.) for 5 seconds each. Preset numbers that do not contain stations are skipped.
3. You can fast forward the preset stations by pressing the **CHANNEL ▶▶** button ⑫ continuously.  
When the desired preset station is received, cancel the preset scan operation by pressing the **CHANNEL ◀◀** button ⑫ or the **CLEAR** button ⑰.

### 5. Clearing Preset Stations

You can remove preset stations from memory using the following procedure.

1. Recall the preset number to be cleared with the method described in "Recalling" a preset station .
2. Press the **CLEAR** button ⑰ on the front panel or **CLEAR** button ⑰ on the remote control unit for 3 seconds or more.  
"CLEAR" appears on the display to indicate that the specified preset number has been cleared.

### 6. Frequency Direct Call

1. Press **F.DIRECT** button ⑱ in the TUNER mode on the remote controller.
2. Display shows "FM- --. -- MHz" (at FM mode).
3. Input your desired frequency with tenkeypad buttons on the remote controller.  
Eg) 98.1 MHz  
Press **9, 8, 1** and **0**
4. Press the **F.DIRECT** button ⑱ again.

### STATION NAME PRESET (On PRESET display mode)

The station name preset function allows the name of each preset channel to be entered using alphanumeric characters. The Station Name button is valid only in the tuner mode. Before station name preset operation, store stations with the preset memory operation.

1. Press the **MEMORY** button **13** on the front panel or **MEMO** button **16** on the remote for more than 3 seconds.
2. The left most column of the station name indicator flashes, indicating the character entry ready status.

#### [Operation (Using the SR5200)]

3. When you press the **TUNING/PRESET** ▲ or ▼ buttons **14** is turned, alphabetic and numeric characters will be displayed in the following order:  
**A → B → C ... Z → 1 → 2 → 3... 0 → - → + → / → (Blank) → A**  
 UP →  
 ← DOWN
4. After selecting the first character to be entered, press the **MEMORY** button **13**. The entry in this column is fixed and the next column starts to flash. Fill the next column and press the **MEMORY** button **13** for more than 1 second to confirm the entry.

#### [Operation (Using the remote control unit)]

First, press the **TUNER** button **3** on the remote control unit.

(This operation is not necessary if the remote control unit has already been operated in the TUNER mode.)

3. Enter the character using the ten keypad **9**. For example, to enter "A":  
 1) Press the "1" button. "A" appears on the display column.  
 2) Every time the 1 button is pressed, the displayed character changes in the order: **A → B → C → 1 → A...**  
 Pressing buttons other than the "1" button cause different characters to be displayed in a similar way, so that other alphanumeric characters can be entered. To enter a blank or space, press the "9" button.
4. When the desired character is displayed, press the **MEMO** button **16** to confirm the entry in this column and move to the next column. After having filled all of the 8 columns, press the **MEMO** button **16**, for more than 1 second to confirm the entry.

## PLAYBACK OPERATION

### NORMAL PLAYBACK

1. Press the **POWER** button **1** / **2**.
2. Press the **FUNCTION SELECTOR** button **5** on the front panel or press the **FUNCTION** button **3** on the remote unit to select an input source.
3. Turn the **SURROUND MODE SELECTOR** knob **3** on the front panel or Surround mode buttons **9** in the AMP MODE on the remote unit to select the desired surround mode.
4. Adjust the volume level using the **VOLUME** knob **4** on the front panel or press the **MAIN VOL.** button **4** on the remote. If necessary, adjust the tone, press the **TRB▲**, **TRB▼** **14** and **BAS▲**, **BAS▼** **15** on the remote unit.

#### Note:

- In case of remote control operation, press one of the function buttons twice within 2 seconds to select the function.
- Tone control is available for following surround modes. AUTO (except 96 kHz), STEREO, DOLBY PRO LOGIC and DTS.

### LISTENING TO A DIFFERENT AUDIO SOURCE WHILE WATCHING A VIDEO SOURCE (Using the remote control unit)

1. Select one of the following video sources  
TV, DVD, VCR1, DSS/VCR2 or AUX.
2. Next, select one of the following audio sources  
FM, AM, CD, TAPE, or CDR/MD.

## TV AUTO ON/OFF FUNCTION

This function allows the component connected to the TV IN jack to control the power (ON/OFF) to the SR5200.

### AUTO POWER ON

1. Be sure TV auto mode is enable. (Refer page 10 : System Setup 1/2)
2. Connect your TV TUNER (etc) to the TV IN terminal.  
Be sure to connect the video input.
3. Turn OFF the power to the TV TUNER and the SR5200 will be in standby mode.
4. Turn ON the TV TUNER and tune in a receivable station.
5. When the station is received, the SR5200 turns ON and TV is selected automatically.

### AUTO POWER OFF

1. In the above situation, turn the TV TUNER OFF or select a channel that does not contain any broadcast.
2. The SR5200 switches to STANDBY after approximately 5 minutes.

#### Note:





AUTO POWER OFF is canceled if the **FUNCTION SELECTOR** button **5** is set to a source other than TV. The function reactivates when TV is selected again.



#### Caution:

Some TV broadcasts may cause the TV AUTO FUNCTION to be turned enable. To set this function to ENABLE/DISABLE, refer to the SETUP MENU.

## SETTING THE SLEEP TIMER





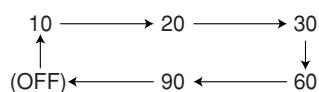

Set the sleep timer while the power is turned on.

1. Turn the power ON and press the **SLEEP** button  / .
2. Press the **SLEEP** button  /  the number of times to set the desired sleep time in minutes.

Each press of the **SLEEP** button  /  or changes the display in the following order:



The unit will shut off in the number of minutes indicated.

- \* While the sleep timer is activated, the remaining time can be displayed for approximately 2 seconds by pressing the **SLEEP** button  / .
- \* To cancel the sleep timer, press the **SLEEP** button  /  and then press the **CLEAR** button  on the front panel or the **CLEAR** button  in the TUNER mode on the remote unit.

## ON SCREEN DISPLAY INFORMATION

The on-screen display, which can be activated by the Main unit or remote, appears on the TV screen to show the current setting status of the SR5200.

### 1. GENERAL INFORMATION

When the **OSD** button  is pressed, the current setting are displayed on the TV monitor.

This display disappears automatically in about 5 seconds after the button is pressed.

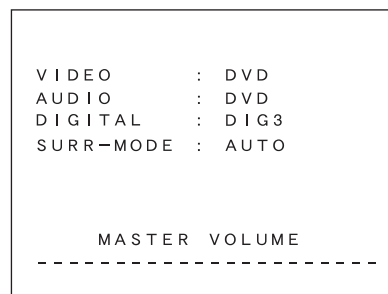

#### ① VIDEO SOURCE:

Displays the current video source being selected with the function selector **TV, DVD, VCR1, DSS** or **AUX**.

#### ② AUDIO SOURCE:

Displays the current audio source being selected with the function selector **FM, AM, CD, TAPE, CD-R, TV, DVD, VCR1, DSS** or **AUX**.

#### ③ DIGITAL INPUT:

Displays the digital input that you are using **DIG-1, DIG-2, DIG-3** or **DIG-4**.

#### ④ SURROUND MODE:

Displays the current surround mode **AUTO, STEREO, 6CH STEREO, VIRTUAL, MATRIX, STADIUM, HALL, MOVIE, 6.1 CH SURR, PLO LOGIC, PLII MUSIC, PLII MOVIE, DTS**

#### ⑤ MASTER VOLUME

Displays the current volume level.  
The volume level is higher at the right of the display.

#### Note:

The On-Screen Display signals can be output from the TV MONI composite video (RCA) output and the TV MONI, S-Video output jacks.

With some video equipment or software, the On-Screen Display characters may be distorted due to noise or tracking adjustment error.

**2. FUNCTION SELECT & SURROUND MODE**

When a function selector button or surround mode button is pressed

**VIDEO:** Displays the current video source. When TV,DSS, DVD, VCR1 or AUX is selected with the function selector, both AUDIO and VIDEO shows the same name.

**AUDIO:** Displays the current analog audio input source.

**DIGITAL:** Displays the current digital input source.

**SURR-MODE:** Displays the current Surround mode as follows;

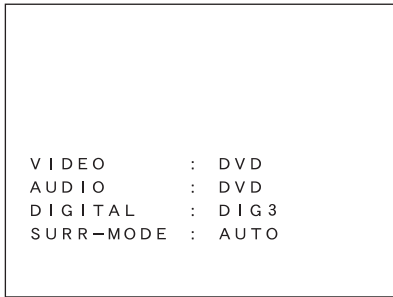
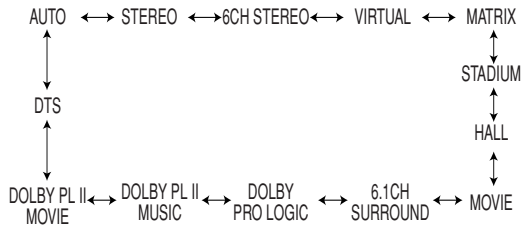

**3. MASTER VOLUME CONTROL**

Displayed when the MASTER volume is varied or a button of the remote control unit is pressed.

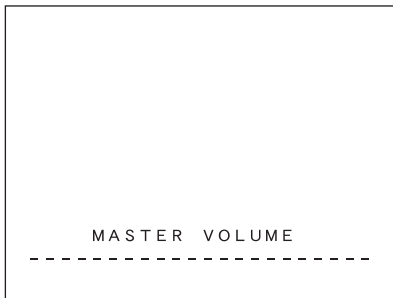

**4. MUTE**

When the MUTE button (11/5) is pressed, "MUTE ON" will be shown on screen.

Pressing MUTE button (11/5) again will show "MUTE OFF" on screen, and return to the previous volume level.



**5. SLEEP TIMER**

When the SLEEP button (9 / 23) is pressed, the setting on or off and the remaining time of the sleep timer function are displayed.

You can change the mode between on, off and the amount of time to elapse before the unit will shut itself off by cycling the SLEEP button (9/23).



**6. OSD OFF**

When OSD button (22) is pressed, OSD system will be bypassed after 3 seconds.

Then there is no indication on the TV display.

Press the OSD button (22) again to activate the OSD.





## SURROUND MODES

The SR5200 incorporates digital signal processors (DSP) which can reproduce various surround effects you experience in concert halls and movie theaters, etc. These Surround Modes, are provided to reproduce a variety of surround sound effects, according to the content of the source to be played.

Surround mode	FEATURES
1. <b>AUTO</b>	When this mode is selected, the receiver determines whether the digital input signal is Dolby Digital, PCM-audio or DTS. <b>Note:</b> When a Dolby Digital or DTS signal is input, the number of channels for which the corresponding signal is encoded will be played. Inputting a Dolby Digital two channel signal with Dolby surround status automatically subjects that signal to Pro Logic II processing before play. 96 kHz source material can be playback in this mode.
2. <b>STEREO</b>	This mode bypasses all surround processing. Stereo program sources the left and right channels play normaly when PCM-audio or analog stereo is input. With Dolby Digital and DTS sources, the 5.1 multi-channels are converted to two channel stereo. 96 kHz source material can be playback in stereo mode.
3. <b>DD</b>  <b>MOVIE</b> <b>MUSIC</b> <b>PRO LOGIC</b>	This mode is used with source materials encoded in Dolby Digital and Dolby Surround. Dolby Pro Logic II brings the excitement of surround sound to any stereo mix, while making existing Dolby Surround mixes sound more like discrete 5.1 channels Surround sound. Dolby Pro Logic II has below 3 modes.  This mode provides 5.1 channel surround sound from Dolby Surround encoded stereo movie sound tracks.  This mode provides 5.1 channel surround sound from conventional stereo sources, analog or digital, such as CD, tape, FM, TV, stereo VCR, etc.  This mode emulated original Dolby Pro Logic decoding (3/1 surround) suit for Dolby Surround encoded stereo movie soundtracks. <b>Note:</b> PCM-audio signals can be subjected to Pro Logic processing when the sampling frequency is 32 kHz, 44.1 kHz or 48 kHz. When a signal in another format is input, output will be muted.
4. <b>DTS</b>	This mode is for DTS encoded source materials such as LASER DISC, CD, and DVD. The DTS mode cannot be used when an Analog input has been selected. When the signal in another digital format is input, output will be muted.
5. <b>6.1CH Surround</b>	This mode reproduces 6.1 channel sound field by extracting the surround center information from surround left and surround right channels. This mode is suited for 6.1 channel encoded material such as Dolby Digital Surround EX and DTS-ES. <b>Note:</b> Dolby Digital 5.1ch and DTS source material can be playback in this mode.
6. <b>MOVIE HALL STADIUM MATRIX</b>	These modes provide surround effect processing from each input source material. They will produce theater, concert hall and stadium like atmospheres. Select as your taste desires. <b>Note:</b> PCM-audio (32 kHz, 44.1 kHz or 48 kHz) and analog source material can playback in this mode.
7. <b>VIRTUAL</b>	This mode create the virtual surround sound with the front right and left speakers. <b>Note:</b> The 96 kHz sampling frequency and DTS source material mute output.
8. <b>6CH STEREO</b>	This mode is used to create a wider, deeper and more natural soundstage from two channel source material. This is done by feeding the left channel signal to both left front and left surround speaker and the right channel signal to both right front and right surround speaker. Additionally, the center channel reproduces a mix of the right and left channel. <b>Note:</b> The 96 kHz sampling frequency mutes output.

### Caution for DTS signal:

This signal can be played when the connected DVD-player, laser-disc player or CD-player is capable of DTS-digital output. For details, refer to the player's operation manual.

Depending on the player used, DTS play may produce noise. If that happens, set the Surround mode to DTS.

Playing a DTS-CD or DTS laser disc causes the player's analog output terminal to output noise. Before playing DTS sources, be sure to connect the player's digital output to the SR5200's digital input. Be careful when connecting the output of these players to analog audio input.

Note that the SR5200 has the following restrictive functions built in to reduce noise emission as much as possible.

If DTS is selected while in the Surround mode, digital input cannot be switched to analog input. When the analog input function has been selected, Surround mode cannot be switched to DTS.

While signals from DTS-laser disc or CD are playing in another Surround mode, you cannot switch to digital input or from digital input to analog input.

### Caution for 96kHz PCM-audio signal:

This signal can be played when a DVD-player or DAT-player connected to the SR5200 is capable of 96 kHz PCM output. For details, refer to the player's operation manual.

The signal can be played when STEREO or AUTO has been selected for the Surround mode.

Some DVD formatted discs featured copy protect. When use such disc, 96 kHz PCM signal is not output from the DVD player. For details, refer to the player's operation manual.



### The relation between the selected surround mode and the input signal

The surround mode is selected with the surround mode selector knob of the SR5200 or the remote control unit. However, the sound from the speakers depend upon the relationship between the selected surround mode and the input signal. They are as follows;

Surround Mode	Input Signal	Output					Fluorescent Indicator			
		L/R	SL/SR	C	SC	SW	Input Indicator	Format Status & Surround Mode	Temporary Display Status	Ch. Status
Auto	Dolby Digital (5.1ch)	O	O	O	-	O	DIGITAL	DOLBY, DIGITAL, AUTO	>AUTO>	L,C,R,SL,SR,LFE
	Dolby Digital (2ch)	O	-	-	-	O	DIGITAL	DOLBY, DIGITAL, AUTO	>AUTO>	L,R
	Dolby Digital (2ch:Lt/Rt)	O	O	O	-	O	DIGITAL	DOLBY, DIGITAL, PRO LOGIC, AUTO	>AUTO>	L,R,SC
	96kHz PCM	O	-	-	-	-	DIGITAL	PCM, STEREO, AUTO	>AUTO>96kHz>	L,R
	PCM(Audio)	O	-	-	-	O	DIGITAL	PCM, STEREO, AUTO	>AUTO>	L,R
	Analog	O	-	-	-	O	ANALOG	STEREO, AUTO	>AUTO>	-
Stereo	DTS (5.1ch)	O	O	O	-	O	DIGITAL	DTS, AUTO	>AUTO>	L,C,R,SL,SR,LFE
	Dolby Digital (5.1ch)	O	-	-	-	O	DIGITAL	DOLBY, DIGITAL, STEREO	>STEREO>	L,C,R,SL,SR,LFE
	Dolby Digital (2ch)	O	-	-	-	O	DIGITAL	DOLBY, DIGITAL, STEREO	>STEREO>	L,R
	Dolby Digital (2ch:Lt/Rt)	O	-	-	-	O	DIGITAL	DOLBY, DIGITAL, STEREO	>STEREO>	L,R,SC
	96kHz PCM	O	-	-	-	-	DIGITAL	PCM, STEREO	>STEREO>96kHz>	L,R
	PCM(Audio)	O	-	-	-	O	DIGITAL	PCM, STEREO	>STEREO>	L,R
Movie	Analog	O	-	-	-	O	ANALOG	STEREO	>STEREO>	-
	DTS (5.1ch)	O	-	-	-	O	DIGITAL	DTS, STEREO	>STEREO>	L,C,R,SL,SR,LFE
	Dolby Digital (5.1ch)	O	O	O	-	O	DIGITAL	DOLBY, DIGITAL	>DOLBY D>	L,C,R,SL,SR,LFE
	Dolby Digital (2ch)	O	O	O	-	O	DIGITAL	DOLBY, DIGITAL, PRO LOGIC	>PLII MOVIE>	L,R
	Dolby Digital (2ch:Lt/Rt)	O	O	O	-	O	DIGITAL	DOLBY, DIGITAL, PRO LOGIC	>PLII MOVIE>	L,R,SC
	96kHz PCM	-	-	-	-	-	DIGITAL	(PCM), DOLBY, PRO LOGIC	>PLII MOVIE>96kHz>	-
Music	PCM(Audio)	O	O	O	-	O	DIGITAL	PCM, DOLBY, PRO LOGIC	>PLII MOVIE>	L,R
	Analog	O	O	O	-	O	ANALOG	DOLBY, PRO LOGIC	>PLII MOVIE>	-
	DTS (5.1ch)	-	-	-	-	-	DIGITAL	(DTS), DOLBY, PRO LOGIC	>PLII MOVIE>	-
	Dolby Digital (5.1ch)	O	O	O	-	O	DIGITAL	DOLBY, DIGITAL	>DOLBY D>	L,C,R,SL,SR,LFE
	Dolby Digital (2ch)	O	O	O	-	O	DIGITAL	DOLBY, DIGITAL, PRO LOGIC	>PLII MUSIC>	L,R
	Dolby Digital (2ch:Lt/Rt)	O	O	O	-	O	DIGITAL	DOLBY, DIGITAL, PRO LOGIC	>PLII MUSIC>	L,R,SC
Pro Logic	96kHz PCM	-	-	-	-	-	DIGITAL	(PCM), DOLBY, PRO LOGIC	>PLII MUSIC>96kHz>	-
	PCM(Audio)	O	O	O	-	O	DIGITAL	PCM, DOLBY, PRO LOGIC	>PLII MUSIC>	L,R
	Analog	O	O	O	-	O	ANALOG	DOLBY, PRO LOGIC	>PLII MUSIC>	-
	DTS (5.1ch)	-	-	-	-	-	DIGITAL	(DTS), DOLBY, PRO LOGIC	>PLII MUSIC>	-
	Dolby Digital (5.1ch)	O	O	O	-	O	DIGITAL	DOLBY, DIGITAL	>DOLBY D>	L,C,R,SL,SR,LFE
	Dolby Digital (2ch)	O	O	O	-	O	DIGITAL	DOLBY, DIGITAL, PRO LOGIC	>PRO LOGIC>	L,R
DTS	Dolby Digital (2ch:Lt/Rt)	O	O	O	-	O	DIGITAL	DOLBY, DIGITAL, PRO LOGIC	>PRO LOGIC>	L,R,SC
	96kHz PCM	-	-	-	-	-	DIGITAL	(PCM), DOLBY, PRO LOGIC	>PRO LOGIC>96kHz>	-
	PCM(Audio)	O	O	O	-	O	DIGITAL	PCM, DOLBY, PRO LOGIC	>PRO LOGIC>	L,R
	Analog	O	O	O	-	O	ANALOG	DOLBY, PRO LOGIC	>PRO LOGIC>	-
	DTS (5.1ch)	-	-	-	-	-	DIGITAL	(DTS), DOLBY, PRO LOGIC	>PRO LOGIC>	-
	Dolby Digital (5.1ch)	-	-	-	-	-	DIGITAL	(DOLBY, DIGITAL), DTS	>DTS>	-
6.1Ch Surround	Dolby Digital (2ch)	-	-	-	-	-	DIGITAL	(DOLBY, DIGITAL), DTS	>DTS>	-
	Dolby Digital (2ch:Lt/Rt)	-	-	-	-	-	DIGITAL	(DOLBY, DIGITAL), DTS	>DTS>	-
	96kHz PCM	-	-	-	-	-	DIGITAL	(PCM), DTS	>DTS>	-
	PCM(Audio)	-	-	-	-	-	DIGITAL	(PCM), DTS	>DTS>	-
	Analog	-	-	-	-	-	(ANALOG)	DTS	>DTS>	-
	DTS (5.1ch)	O	O	O	-	O	DIGITAL	DTS	>DTS>	L,C,R,SL,SR,LFE
Movie Hall Stadium Matrix	Dolby Digital (5.1ch)	O	O	O	O	O	DIGITAL	DOLBY, DIGITAL	>6.1 CH SURROUND>	L,C,R,SL,SR,LFE
	Dolby Digital (2ch)	-	-	-	-	-	DIGITAL	(DOLBY, DIGITAL)	>6.1 CH SURROUND>	-
	Dolby Digital (2ch:Lt/Rt)	-	-	-	-	-	DIGITAL	(DOLBY, DIGITAL)	>6.1 CH SURROUND>	-
	96kHz PCM	-	-	-	-	-	DIGITAL	(PCM)	>6.1 CH SURROUND>	-
	PCM(Audio)	-	-	-	-	-	DIGITAL	(PCM)	>6.1 CH SURROUND>	-
	Analog	-	-	-	-	-	(ANALOG)	DTS	>6.1 CH SURROUND>	-
Virtual	DTS (5.1ch)	O	O	O	O	O	DIGITAL	DTS	>6.1 CH SURROUND>	L,C,R,SL,SR,LFE
	Dolby Digital (5.1ch)	-	-	-	-	-	DIGITAL	(DOLBY, DIGITAL), DSP SOUND	>MOVIE/HALL/ STADIUM/MATRIX>	-
	Dolby Digital (2ch)	-	-	-	-	-	DIGITAL	(DOLBY, DIGITAL), DSP SOUND	>MOVIE/HALL/ STADIUM/MATRIX>	-
	Dolby Digital (2ch:Lt/Rt)	-	-	-	-	-	DIGITAL	(DOLBY, DIGITAL), DSP SOUND	>MOVIE/HALL/ STADIUM/MATRIX>	-
	96kHz PCM	-	-	-	-	-	DIGITAL	(PCM), DSP SOUND	>MOVIE/HALL/ STADIUM/MATRIX>	-
	PCM(Audio)	O	O	O	-	O	DIGITAL	PCM, DSP SOUND	>MOVIE/HALL/ STADIUM/MATRIX>	L,R
6CH Stereo	Analog	O	O	O	-	O	ANALOG	DSP SOUND	>MOVIE/HALL/ STADIUM/MATRIX>	-
	DTS (5.1ch)	-	-	-	-	-	DIGITAL	(DTS), DSP SOUND	>MOVIE/HALL/ STADIUM/MATRIX>	-
	Dolby Digital (5.1ch)	O	-	-	-	-	DIGITAL	DOLBY, DIGITAL, VIRTUAL	>VIRTUAL>	L,C,R,SL,SR,LFE
	Dolby Digital (2ch)	O	-	-	-	-	DIGITAL	DOLBY, DIGITAL, PROLOGIC, VIRTUAL	>VIRTUAL>	L,R
	Dolby Digital (2ch:Lt/Rt)	O	-	-	-	-	DIGITAL	DOLBY, DIGITAL, PROLOGIC, VIRTUAL	>VIRTUAL>	L,R,SC
	96kHz PCM	-	-	-	-	-	DIGITAL	(PCM)	>VIRTUAL>96kHz>	-
6CH Stereo	PCM(Audio)	O	-	-	-	-	DIGITAL	PCM, DOLBY, PROLOGIC, VIRTUAL	>VIRTUAL>	L,R
	Analog	O	-	-	-	-	ANALOG	DOLBY, PROLOGIC, VIRTUAL	>VIRTUAL>	-
	DTS (5.1ch)	-	-	-	-	-	DIGITAL	(DTS), DOLBY, VIRTUAL	>VIRTUAL>	-
	Dolby Digital (5.1ch)	O	O	O	-	O	DIGITAL	DOLBY, DIGITAL	>6CH STEREO>	L,C,R,SL,SR,LFE
	Dolby Digital (2ch)	O	O	O	O	O	DIGITAL	DOLBY, DIGITAL	>6CH STEREO>	L,R
	Dolby Digital (2ch:Lt/Rt)	O	O	O	O	O	DIGITAL	DOLBY, DIGITAL	>6CH STEREO>	L,R,SC
6CH Stereo	96kHz PCM	-	-	-	-	-	DIGITAL	(PCM)	>6CH STEREO>96kHz>	-
	PCM(Audio)	O	O	O	O	O	DIGITAL	PCM	>6CH STEREO>	L,R
	Analog	O	O	O	O	O	ANALOG	PCM	>6CH STEREO>	-
	DTS (5.1ch)	O	O	O	-	O	DIGITAL	DTS	>6CH STEREO>	L,C,R,SL,SR,LFE

L/R : Front speaker  
 SL/SR : Surround speaker  
 C : Center speaker  
 SC : Surround center speaker  
 SW : Sub woofer speaker

( ) : The indicator blinks

L : Left  
 R : Right  
 C : Center  
 SL : Surround Left  
 SR : Surround Right  
 SC : Mono Surround  
 LFE : Low Frequency Effect

**Note:**

- Dolby Digital (2 ch: Lt/Rt): signal with Dolby Surround flag Speakers are full set.
- When DOLBY DIGITAL, DTS, PCM or ANALOG is blinking, the selected surround mode is unavailable for input signal. Select the other appropriate surround mode to playback.
- No sound outputs from the surround speaker, center speaker and subwoofer if the DVD disc has no surround data.

# TROUBLE SHOOTING

In case of trouble, check the following before calling for service:

1. Are the connections made properly ?
2. Are you operating the unit properly following user's guide ?
3. Are the power amplifiers and speaker working properly ?

If the unit does not operate properly, check items shown in the following table.

If your trouble cannot be recovered with the remedy actions listed in the following table, malfunction of the internal circuitry is suspected; immediately unplug the power cable and contact your dealer, nearest Marantz distributor or the Marantz Service Center in your country.

SYMPTOM	CAUSE	REMEDY
SR5200 cannot be turned up.	The power plug is not connected.	Connect the power plug to the outlet.
No sound and picture are output even when power is on.	Mute is on. The input cable is not connected correctly. The master volume control is turned all the way down. The function selector position is wrong.	Cancel mute using the remote control unit. See the connection diagram and connect the cables correctly. Adjust the master volume. Select correct position.
Speaker does not outputting any sound.	The headphones are connected to the headphone jack.	Disconnect the headphones. (Speakers will not output sound when headphones are connected.)
Sound and pictures from other than equipment selected with the function selector.	Input cable connected incorrectly.	Connect the cable correctly by referring to the connection diagram.
Sound from the wrong channel is output from the speaker.	Speaker cable connected incorrectly.	Connect the cable correctly by referring to the connection diagram.
No sound is output from the center speaker.	The center speaker cable connection is incomplete. STEREO has been selected for Surround mode.  Center = NONE has been selected in SETUP mode.	Connect the cable correctly. When STEREO is selected for Surround mode, no sound will be output from the center speaker. Set another Surround mode. Make the correct setting.
No sound is output from the surround speakers.	The surround speaker cable connection is incomplete. STEREO has been selected for Surround mode.  Surround = NONE has been selected in SETUP mode.	Connect the cable correctly. When STEREO has been selected for Surround mode, no sound will be output from the surround speaker. Set another Surround mode. Make the correct setting.
No output to Sub Woofer Out.	Sub-woofer = NO has been selected in SETUP mode.	Select Sub-woofer = YES.
Surround mode cannot be changed.	The headphones are connected to the jack.	Disconnect the headphones. (When headphones are connected, Surround mode will be fixed to STEREO.)
Noise is produced during DTS-encoded CD or laser disc play.	Analog has been selected for input.	Be sure to perform digital connection, select digital input, then play.
DTS sources cannot be played.	Surround mode is set to DOLBY. The DVD or LD player is not DTS digital out capable.	Select other mode. Use a player which responds to DTS-digital out.
Player skips during play of a DTS source and produces noise.	Data error occurred during player skip.	Set Surround mode to DTS.
A 96kHz PCM signal cannot be played.	The disc player is not 96kHz PCM digital out capable. Surround mode is set to other than STEREO and AUTO.	Use a player that responds to 96kHz PCM digital out. Set Surround mode to STEREO or AUTO.
A normal PCM signal (CD or laser disc) cannot be played.	Surround mode is set to DTS.	Select other mode.
A Dolby Digital signal cannot be played.	Surround mode is set to DTS	Select other mode.
A specific channel does not produce output.	Nothing recorded on source.	Check the encoded channel on the source side.
FM or AM reception fails.	Antenna connection is incomplete.	Correctly connect the indoor FM and AM antennas to FM and AM antenna outlets.
Noise is heard during AM reception.	Reception is affected by other electrical fields.	Try changing location where the AM indoor antenna is set up.
Noise is heard during FM reception.	The radio waves from the broadcasting station are weak.	Install an FM outdoor antenna.
Cannot get programmed station when the PRESET button is pressed.	Preset data has been erased.	Disconnecting power plug for long periods of time will erase preset data. If that happens, input the preset data again.
Nothing appears on the remote commander display.	Batteries are consumed.	Replace all the batteries with new ones.
Control with the remote control unit fails.	Batteries are consumed.. Remote controller's function-key setting is wrong. The distance between this SR5200 and the remote commander is too far. Something is blocking SR5200 and the remote commander.	Replace all the batteries with new ones.. Select different position from which equipment will be controlled. Move closer to this SR5200.  Remove offending object.

**GENERAL MALFUNCTION**

If the equipment malfunctions, this may be because an electrostatic discharge or AC line interference has corrupted the information in the equipment memory circuits. Therefore:

- disconnect the plug from the AC line supply
- after waiting at least three minutes, reconnect the plug to the AC line supply
- re-attempt to operate the equipment

**Memory backup**

- In case a power outage occurs or the power cord is accidentally unplugged, the SR5200 is equipped with a backup function to prevent memory data such as the preset memory from being erased.

The memory functions are backed up for up to about one week.

**NOTE:**

First of all keep SR5200 Standby or Powered-on more than 6 hours, to sufficient time for memory back up.

# SETUP CODES

## CD

Aiwa	0151, 0184
Burmester	0447
California Audio Labs	0056, 0330
Carver	0184, 0206, 0326, 0464
DKK	0027
Denon	0030
Emerson	0332
Fisher	0201, 0206
Garrard	0420, 0447
Genexxa	0059, 0332
Harman/Kardon	0184, 0200
Hitachi	0059
JVC	0099
Kenwood	0055, 0064, 0217
Krell	0184
LXI	0332
Linn	0184
Luxman	0062, 0120, 0293, 0354, 0355, 0457, 0459, 0510, 0516
MCS	0056
MTC	0447
Magnavox	0184, 0332
Marantz	0056, 0184, 0207, 1207, 0999,
Mission	0184
NAD	0046, 0326, 0343, 0747, 0748
NSM	0184
Nakamichi	0106, 0174, 0466, 0471, 0691
Nikko	0201
Onkyo	0128
Optimus	0027, 0059, 0064, 0172, 0206, 0332, 0447, 0464, 0495
Panasonic	0056, 0330
Parasound	0447
Philips	0184
Pioneer	0059, 0271, 0332, 0495
Polk Audio	0184
Proton	0184
QED	0184
Quasar	0056
RCA	0059, 0080, 0206, 0332, 0495, 0791
Realistic	0206, 0207, 0447
Rotel	0184, 0447
SAE	0184
Sansui	0184, 0332
Sanyo	0206
Scott	0332
Sears	0332
Sharp	0064, 0207
Sherwood	0207
Sonic Frontiers	0184
Sony	0027, 0212
Soundesign	0172
Tascam	0447
Teac	0201, 0207, 0420, 0447
Technics	0056, 0330
Toshiba	0046, 0326
Victor	0099
Wards	0080, 0184
Yamaha	0063, 0214
Yorx	0488

## MD PLAYERS

Denon	1900
Kenwood	1708, 1853
Marantz	1207
Onkyo	1895
Optimus	1090
Pioneer	1090
Sharp	1888
Sherwood	1094
Sony	1517
Yamaha	1915

## CDR

Marantz	0999
---------	------

## TAPE

Aiwa	0056, 0224
Carver	0056
Denon	0103
Garrard	0335, 0336
Harman/Kardon	0056, 0209
JVC	0271, 0300
Kenwood	0097
Magnavox	0056
Marantz	0056
NAD	0171
Onkyo	0162, 0309
Optimus	0054, 0247
Panasonic	0256
Philips	0056
Pioneer	0054, 0126, 0247
Polk Audio	0056
RCA	0054, 0247
Samsung	0418, 0419
Sansui	0056
Sony	0197, 0270, 0318
Teac	0307, 0335, 0336, 0418, 0419
Technics	0256
Victor	0300
Wards	0054
Yamaha	0121, 0124

## SAT (DSS)

AlphaStar	0799
Echostar	0802, 1032
Expressvu	0802
General Instrument	0388, 0654, 0896
HTS	0802
Hitachi	0846
Hughes Network Systems	0776
JVC	0802
Jerrold	0388, 0654
Magnavox	0749, 0751
Memorex	0751
Next Level	0896
Panasonic	0728
Philips	0749, 0751, 1103
Primestar	0388, 0654
RCA	0170, 0419, 0593, 0882
Radio Shack	0896
Sony	0666
Star Choice	0896
Toshiba	0776, 0817
Uniden	0749, 0751
Zenith	0883

**TV**

AOC ..... 0046, 0057  
Admiral ..... 0120, 0490  
Aiko ..... 0119  
Akai ..... 0057  
Alaron ..... 0206  
Ambassador ..... 0204  
America Action ..... 0207  
Anam ..... 0207  
Audiovox ..... 0119, 0207, 0478, 0650  
Baysonic ..... 0207  
Belcor ..... 0046  
Bell & Howell ..... 0043, 0181  
Bradford ..... 0207  
Brockwood ..... 0046  
Broksonic ..... 0263, 0490  
CXC ..... 0207  
Candle ..... 0057, 0083  
Carnivale ..... 0057  
Carver ..... 0081  
Celebrity ..... 0027  
Cineral ..... 0119, 0478  
Citizen ..... 0057, 0083, 0087, 0119  
Concerto ..... 0083  
Contec ..... 0207  
Craig ..... 0207  
Crosley ..... 0081  
Crown ..... 0207  
Curtis Mathes ..... 0043, 0057, 0074, 0078, 0081, 0083, 0087,  
0120, 0172, 0181, 0193, 0478, 1174, 1374  
Daewoo ..... 0046, 0119, 0478, 0650, 0651  
Daytron ..... 0046  
Denon ..... 0172  
Dumont ..... 0044, 0046  
Dwin ..... 0747, 0801  
Electroband ..... 0027  
Emerson ..... 0046, 0181, 0204, 0205, 0206, 0207, 0263, 0490,  
0650, 0651  
Envision ..... 0057  
Fisher ..... 0181  
Fujitsu ..... 0206, 0710  
Funai ..... 0206, 0207  
Futuretech ..... 0207  
GE ..... 0074, 0078, 0120, 0205, 0478, 1174, 1374  
Gibraltar ..... 0044, 0046, 0057  
GoldStar ..... 0046, 0057, 0083, 0205  
Gradiente ..... 0080, 0083  
Grunpy ..... 0206, 0207  
Hallmark ..... 0205  
Harley Davidson ..... 0206  
Harman/Kardon ..... 0081  
Harvard ..... 0207  
Hitachi ..... 0043, 0083, 0172  
Infinity ..... 0081  
Inteq ..... 0044  
JBL ..... 0081  
JCB ..... 0027  
JVC ..... 0080  
KEC ..... 0207  
KTV ..... 0057, 0207  
Kenwood ..... 0046, 0057  
LG ..... 0083  
LXI ..... 0074, 0081, 0181, 0183, 0205  
Logik ..... 0043  
Luxman ..... 0083  
MGA ..... 0046, 0057, 0177, 0205  
MTC ..... 0046, 0057, 0083, 0087  
Magnavox ..... 0057, 0081, 0206, 1281

Majestic ..... 0043  
Marantz ..... 0057, 0081, 1581  
Matsushita ..... 0277  
Megatron ..... 0172, 0205  
Memorex ..... 0043, 0083, 0177, 0181, 0205, 0206, 0277, 0490  
Midland ..... 0044, 0074, 0078  
Mitsubishi ..... 0046, 0120, 0177, 0205  
Motorola ..... 0120  
Multitech ..... 0207  
NAD ..... 0183, 0193, 0205  
NEC ..... 0046, 0057, 0083  
NTC ..... 0119  
Nikko ..... 0057, 0119, 0205  
Onwa ..... 0207  
Optimus ..... 0181, 0193, 0277  
Optonica ..... 0120, 0192  
Orion ..... 0206, 0263, 0490  
Panasonic ..... 0078, 0277  
Penney ..... 0046, 0057, 0074, 0078, 0083, 0087, 0183, 0205, 1374  
Philco ..... 0046, 0057, 0081, 0172, 0490  
Philips ..... 0081  
Pilot ..... 0046, 0057  
Pioneer ..... 0193, 0706  
Portland ..... 0046, 0119  
Prism ..... 0078  
Proscan ..... 0074  
Proton ..... 0205  
Pulsar ..... 0044, 0046  
Quasar ..... 0078, 0192, 0277  
RCA ..... 0046, 0074, 0078, 0117, 0120, 0706, 1074,  
1174, 1274, 1374, 1474  
Radio Shack ..... 0046, 0057, 0074, 0083, 0181, 0192, 0205, 0207  
Realistic ..... 0046, 0057, 0083, 0181, 0192, 0205, 0207  
Runco ..... 0044, 0057, 0630  
SSS ..... 0046, 0207  
Sampo ..... 0057  
Samsung ..... 0046, 0057, 0083, 0087, 0205  
Sansei ..... 0478  
Sansui ..... 0490  
Sanyo ..... 0181  
Scimitsu ..... 0046  
Scotch ..... 0205  
Scott ..... 0046, 0205, 0206, 0207, 0263  
Sears ..... 0074, 0081, 0083, 0181, 0183, 0205, 0206  
Semivox ..... 0207  
Semp ..... 0183  
Sharp ..... 0120, 0192, 0715  
Shogun ..... 0046  
Signature ..... 0043  
Sony ..... 0027  
Soundesign ..... 0205, 0206, 0207  
Starlite ..... 0207  
Supreme ..... 0027  
Sylvania ..... 0057, 0081  
TMK ..... 0083, 0204, 0205  
TNCi ..... 0044  
Tandy ..... 0120  
Technics ..... 0078, 0277  
Technol Ace ..... 0206  
Techwood ..... 0078, 0083  
Teknika ..... 0043, 0046, 0081, 0083, 0087, 0119, 0177, 0206, 0207  
Telefunken ..... 0083  
Toshiba ..... 0087, 0181, 0183, 1283  
Vector Research ..... 0057  
Victor ..... 0080  
Vidikron ..... 0081  
Vidtech ..... 0046, 0205  
Wards ..... 0043, 0046, 0057, 0081, 0083, 0192, 0205, 0206  
White Westinghouse ..... 0490, 0650, 0651  
Yamaha ..... 0046, 0057  
Zenith ..... 0043, 0044, 0119, 0490, 0651

**VCR**

Admiral ..... 0075, 0236  
Adventura ..... 0027  
Aiko ..... 0305  
Aiwa ..... 0027, 0064  
America Action ..... 0305  
American High ..... 0062  
Asha ..... 0267  
Audiovox ..... 0064  
Beaumarck ..... 0267  
Bell & Howell ..... 0131  
Broksonic ..... 0148, 0211, 0236, 0506  
CCE ..... 0099, 0305  
Calix ..... 0064  
Canon ..... 0062  
Carver ..... 0108  
Cineral ..... 0305  
Citizen ..... 0064, 0305  
Colt ..... 0099  
Craig ..... 0064, 0074, 0099, 0267  
Curtis Mathes ..... 0062, 0087, 0189  
Cybernex ..... 0267  
Daewoo ..... 0072, 0305  
Denon ..... 0069  
Dynatech ..... 0027  
Electrohome ..... 0064  
Electroponic ..... 0064  
Emerex ..... 0059  
Emerson ..... 0027, 0064, 0070, 0148, 0211, 0236, 0305, 0506  
Fisher ..... 0074, 0131  
Fuji ..... 0062  
Funai ..... 0027  
GE ..... 0062, 0075, 0087, 0267  
Garrard ..... 0027  
Go Video ..... 0459  
GoldStar ..... 0064  
Gradiente ..... 0027  
HI-Q ..... 0074  
Harley Davidson ..... 0027  
Harman/Kardon ..... 0108  
Harwood ..... 0099  
Hitachi ..... 0027, 0069  
Hughes Network Systems ..... 0069  
JVC ..... 0094  
KEC ..... 0064, 0305  
KLH ..... 0099  
Kenwood ..... 0094  
Kodak ..... 0062, 0064  
LXI ..... 0064  
Lloyd's ..... 0027  
Logik ..... 0099  
MEI ..... 0062  
MGA ..... 0070, 0267  
MGN Technology ..... 0267  
MTC ..... 0027, 0267  
Magnasonic ..... 0305  
Magnavox ..... 0027, 0062, 0066, 0108  
Magnin ..... 0267  
Marantz ..... 0062, 0108, 1408  
Marta ..... 0064  
Matsushita ..... 0062, 0189  
Memorex ..... 0027, 0062, 0064, 0066, 0074, 0075, 0131, 0189,  
0236, 0267, 0506, 1064, 1189, 1289  
Minolta ..... 0069  
Mitsubishi ..... 0070, 0075, 0094  
Motorola ..... 0062, 0075  
Multitech ..... 0027, 0099  
NAD ..... 0085

NEC ..... 0094, 0131  
Nikko ..... 0064  
Noblex ..... 0267  
Olympus ..... 0062  
Optimus ..... 0064, 0075, 0085, 0131, 0189, 0459, 1075, 1089,  
1189, 1289  
Orion ..... 0211, 0236, 0506  
Panasonic ..... 0062, 0189, 0252, 0643, 1089, 1189, 1289  
Penney ..... 0062, 0064, 0069, 0267  
Pentax ..... 0069  
Philco ..... 0062, 0236, 0506  
Philips ..... 0062, 0108, 0645, 1108, 1208  
Pilot ..... 0064  
Pioneer ..... 0085, 0094  
Polk Audio ..... 0108  
Profitronic ..... 0267  
Proscan ..... 0087  
Protec ..... 0099  
Pulsar ..... 0066  
Quasar ..... 0062, 0189, 1189  
RCA ..... 0062, 0069, 0075, 0085, 0087, 0267  
Radio Shack ..... 0027, 1064  
Radix ..... 0064  
Randex ..... 0064  
Realistic ..... 0027, 0062, 0064, 0074, 0075, 0131  
ReplayTV ..... 0641, 0643  
Runco ..... 0066  
STS ..... 0069  
Samsung ..... 0072, 0267  
Sanky ..... 0066, 0075  
Sansui ..... 0027, 0094, 0236, 0506  
Sanyo ..... 0074, 0131, 0267  
Scott ..... 0070, 0072, 0148, 0211  
Sears ..... 0027, 0062, 0064, 0069, 0074, 0131  
Semp ..... 0072  
Sharp ..... 0075  
Shintom ..... 0099  
Shogun ..... 0267  
Singer ..... 0099  
Sony ..... 0027, 0059, 0062, 1059  
Sylvania ..... 0027, 0062, 0070, 0108  
Symphonic ..... 0027  
TMK ..... 0267  
Teac ..... 0027  
Technics ..... 0062, 0189  
Teknika ..... 0027, 0062, 0064  
Thomas ..... 0027  
Tivo ..... 0645  
Toshiba ..... 0070, 0072  
Totevision ..... 0064, 0267  
Unitech ..... 0267  
Vector ..... 0072  
Video Concepts ..... 0072  
Videasonic ..... 0267  
Wards ..... 0027, 0062, 0069, 0074, 0075, 0087, 0099, 0108, 0267  
White Westinghouse ..... 0099, 0236, 0305  
XR-1000 ..... 0027, 0062, 0099  
Zenith ..... 0027, 0066, 0236, 0506

**DVD**

Aiwa ..... 0668  
Apex ..... 0699  
Denon ..... 0517, 0661  
Fisher ..... 0697  
GE ..... 0549  
Harman/Kardon ..... 0609  
Hitachi ..... 0691  
Hiteker ..... 0699  
JVC ..... 0585, 0650  
Kenwood ..... 0561, 0709  
Magnavox ..... 0530, 0702  
Marantz ..... 0566  
Mitsubishi ..... 0548  
Onkyo ..... 0530, 0654  
Optimus ..... 0598  
Oritron ..... 0678  
Panasonic ..... 0517, 0659  
Philips ..... 0530, 0566  
Pioneer ..... 0552, 0598, 0659  
Proscan ..... 0549  
RCA ..... 0549, 0598  
Samsung ..... 0600  
Sharp ..... 0657  
Sony ..... 0560  
Technics ..... 0517  
Theta Digital ..... 0598  
Toshiba ..... 0530  
Yamaha ..... 0517, 0572  
Zenith ..... 0530, 0618

# TECHNICAL SPECIFICATIONS

## FM TUNER SECTION

Frequency Range .....	87.5 - 108.0 MHz
Usable Sensitivity .....	IHF 1.8 $\mu$ V/16.4 dBf
Signal to Noise Ratio .....	Mono/Stereo 76/72 dB
Distortion .....	Mono/Stereo 0.2/0.3 %
Stereo Separation .....	1 kHz 45 dB
Alternate Channel Selectivity .....	$\pm$ 400 kHz 60 dB
Image Rejection .....	98 MHz 70 dB
Tuner Output Level .....	1 kHz, $\pm$ 75 kHz Dev 800 mV

## AM TUNER SECTION

Frequency Range .....	AM: 520 - 1710 kHz
Signal to Noise Ratio .....	50 dB
Usable Sensitivity .....	Loop 400 $\mu$ V/m
Distortion .....	400 Hz, 30 % Mod. 0.5 %
Selectivity .....	$\pm$ 20 kHz 60 dB

## AUDIO SECTION

Continuous Power Output (8 ohms / 20 Hz - 20 kHz)	
Front .....	90 W
Center .....	90 W
Surround .....	90 W
THD Front (20 Hz - 20 kHz) .....	8 ohms 0.05 %
Input Sensitivity/Impedance	
Linear .....	340 mV/ 47 Kohms
Signal to Noise Ratio	
Linear .....	105 dB

## VIDEO

Television Format .....	NTSC
Input Level/Impedance .....	1 Vp-p/ 75 ohms
Output Level/Impedance .....	1 Vp-p/ 75 ohms
Video Frequency Response .....	5 Hz to 8 MHz (- 1 dB)
S/N .....	60 dB

## GENERAL

Power Requirement .....	AC 120 V 60 Hz
Power Consumption .....	3.6 A
Dimension (MAX)	
Width .....	17-3/8 inches (440 mm)
Height .....	6-1/2 inches (164 mm)
Depth .....	15-3/4 inches (400 mm)
Weight .....	28.5 lbs (12.9 Kg)

## ACCESSORIES

Remote Control Unit RC5200SR .....	1
AAA-size batteries .....	2
FM Feeder Antenna .....	1
FM Antenna Converter .....	1
AM Loop Antenna .....	1
Warranty Card (for USA) .....	1
Warranty Card (for CANADA) .....	1
User Guide .....	1

Specifications subject to change without prior notice.



COUNTRY	COMPANY	ADDRESS
ALGERIE	Azur 2000	8, Lotissement Ben Hatadi, Alger, Algeria
ARMENIA	NGYIG Ltd.	47 A/75 St. Lalaïants, 375000 Yerevan, Armenia
AUSTRALIA	Jamo Australia Pty. Ltd.,	24 Lionel Road, Mt. Waverley, VIC 3149, Australia
AUSTRIA	Huber & Prohaska GmbH	Taborstraße 95 / Ladestraße 1, Gebäude Hangartner, A-1200 Wien, Austria
BAHREIN	Ambassador Stores	P.O. Box 237,141, Government Avenue, Manama,Bahrein
BANGLADESH	Target	1078, Ramjoy Mohanja Lane Asadonj, Chittagong 4000, Bangladesh
BELGIUM	Van der Heyden Audio N.V.	Brusselbaan 278, 9320 Ereembodegem, Belgium
BULGARIA	Ariescommerce GmbH	Makedonia Blvd. 16, 1606 Sofia, Bulgaria
CANADA	Lenbrook Industries Limited	633 Granite Court, Pickering, Ontario
CHINA	Guang Chang Audio International Co., Ltd.	No.38 Yushan Road, ShiQiao, Pan Yu, Guang Dong, China
CYPRUS	Empire Hifi systems Ltd.	P.O. Box 5604, Nicosia, Cyprus
CZECH REPUBLIC	Audio International	Sokolska 41, 67902 Rajecsko, OKR,Blansko, Czech Republic
DENMARK	Audio Nord	Dali Allé 1, 9610 Noerager, Denmark
DUBAI	V.V.& SONS	P.O. Box 105, Dubai, U.A.E.
EGYPT	Solimco	9, El Attibaa St. Doki, Cairo, Egypt
ESTONIA	HiFi Club Estonia	Ehte 4, 90503 Haapsalu, Estonia
F.Y.R.O.M.	T.P. KODI	ul.Cedomir Kantargiev 21a, Skopje, Former Yugoslavian Republic of Macedonia
FINLAND	Audio Nord	Uudenmaankatu 4-6, Helsinki SF-00120, Finland
FRANCE	Marantz France	A division of Marantz Europe B.V., P.O. Box 301, 92 156 Suresnes Cedex, France
GERMANY	Marantz Deutschland	Hakenbusch 3, 49078 Osnabrück, Germany
GREECE	Adamco S.A.	188, Hippocratous Street, 11471 Athens, Greece
HEADQUARTERS EUROPE:	Marantz Europe B.V.	Building SFF-2, P.O. Box 80002, 5600 JB Eindhoven, The Netherlands
HONG KONG	Marantz Asia Ltd.	Unit 1706, Metroplaza II, 223 Hing Fong Road, Kwai Fong, N.T., Kowloon, Hong Kong
HUNGARY	Infovox Ltd.	Terez Krt.31, 1067 Budapest, Hungary
ICELAND	ID Electronics Ltd.	Armula 38, 108 Reykjavik, Iceland
INDIA	NOVA Audio Private	8,Punam Co-op.Society 29/30 Road#5, Union Park MUMBAI 400052, India
IRAN	Home Co.	5th floor no 878 Philips Building Enghelab ave, P.O. 11365/7844 Tehran, Iran
IRELAND	Marantz Ireland	Clonskeagh, Dublin 14, Ireland
ISRAEL	Elmor Ltd.	52 Heh Beiyar Street, Kikar Hamedina, Tel Aviv, Israel
ITALY	Marantz Italy	Via Casati 23, 20052 Monza (Milano), Italy, Servizio Consumatori 1678-20026, Numero Verde
IVORY COAST	Hifivoir	B.P. 2428, Abidjan 01, Ivory Coast
JAPAN	Marantz Japan Inc.	35-1 Sagami Ohno 7-Chome, Sagamihara-shi, Kanagawa 228-8505, Japan
KOREA	Mk Enterprises Ltd.	121-210, 2F Shinhan Bldg., 247-17 Seokyo-dong, Mapo-ku, Seoul, Korea
KUWAIT	alAlamiah Electronics Intl.	P.O. Box 8196, Salmiah 22052, Kuwait
LATVIA	Ace Ltd.	61, LacPlesa Str., Riga LV 1011, Latvia
LEBANON	AZ Electronics S.A., 1,	P.O. Box 11 2833, Beirut, Lebanon
LITHUANIA	Accapella Ltd.	Ausros, Vartu G/5, Pasazo SKG., 2001 Vilnius, Lithuania
MALAYSIA	Wo Kee Hong Electronics Sdn. Bhd.	Suite 8.1, Level 8, Menara Genesis, No. 33, Jalan Sultan Ismail, 50250 Kuala Lumpur, Malaysia
MALTA	Doneo Co Ltd.	78 The Strand, Sliema SLM07, Malta
MAURITIUS	SKR Electronics Ltd.	P.O. Box 685, Bell Village, Port Louis, Mauritius
MILITARY MARKET EUROPE	PASCO GmbH	PO BOX 1280, Sandhausen 69200, Germany
NETHERLANDS	Marantz Domestic Sales	A division of Marantz Europe B.V., Building SFF2, P.O. Box 80002, 5600 JB Eindhoven, The Netherlands
NEW ZEALAND	Wildash Audio Systems	14 Malvern Road, Mt. Albert, Auckland, New Zealand
NORWAY	Audio Nord	Sandkerveien 64, Oslo 0483, Norway
OMAN	Mustafa & Jawad Trading CO.	P.O. Box 1918, Ruwi, Oman
POLAND	Philips Polska Sp. z.o.o.	Al.Jerozolimskie 195b, 02 222 Warszawa, Poland
PORTUGAL	Corel2	Comércio de Electrónica Lda., Av. Luís Bivar, No 85 A, 1050 Lisboa, Portugal
PROFESSIONAL EUROPE	Marantz Professional Products	Kingsbridge House, Padbury Oaks, 575-583 Bath Road, Longford, Middlesex UB7 0EH, U.K.
PROFESSIONAL U.S.A.	Marantz Professional Products	Distributed by: Superscope Technologies Inc., 1000 Corporate Blvd. Ste.D, Aurora, Illino
QATAR	Almana & Partners W.W.L.	P.O. Box 49, Doha, Qatar
REUNION	Vision +	180 Rue du Marechal Leclerc, 97400 Saint Denis, Ile de la Reunion
ROMANIA	Nova Music Entertainment	5, Zagazului Str. Bl.1G,apt.18, sector 1,Bucharest, Romania
RUSSIA	Absolute Audio	7/2, Montazhnaya Street, 107497 Moscow, Russia
SAUDI ARABIA	Adawlia Univ. Electr. Apl	P.O. Box 2154, Alkhobar 31952, Saudi Arabia
SINGAPORE	Wo Kee Hong Distribution PTE Ltd.	130 Joo Seng Road, #03-02 Olivine Building, Singapore 368357
SLOVAKIA	Bis Audio s.r.o.	Nam. SNP 10, 96001 Zvolem, Slovakia
SLOVENIA	Bofex	Smartinska 152, HALA V/3, 61000 Ljubljana, Slovenia
SOUTH AFRICA	Coherent Imports (PTY) Ltd.	P.O. Box 1614, Alberton, 1450, South Africa
SPAIN	Marantz Spain	Martinez Villergas 2, Apartado 2065, Madrid 28027, Spain
SRI LANKA	The listening Room	Mezzanine Floor, The Landmark 385, Galle Road, Colombo - 3, Sri Lanka
SWEDEN	Audio Nord	Almedalsvagen 4, Gotenborg 402-23, Sweden
SWITZERLAND	Sound Company AG	Postfach, 8010 Zürich, Switzerland
SYRIA	Hamzeh & Partners	Hafez Ibrahim Str. No 117, Damascus Shalan, Syria
TAHITI	Covecolor	Av. Prince Hinoi, Cours de l'union sacré, P.O. Box 2334, Papeete, Tahiti
TAIWAN	Pai-Yuing Co. Ltd.	6th No 148 Sung Kiang Road, Taipei 10429, Taiwan R.O.C.
THAILAND	MRZ Standard Co. Ltd.	746-750 Mahachai Road, Wangburapa, Bangkok 10200, Thailand
TUNESIA	Societe EDEVIG	40, Avenue du Golfe Arabe, El Menzah, 1004, Tunesia
TURKEY	Türk Philips Ticaret A.S.	Yukari Dudullu Organize sanayi Bolgesi, 2.Cadde no.28, 81260 Umraniye-Istanbul, Turkey
U.K.	Marantz Hifi UK Ltd.	Kingsbridge House, Padbury Oaks, 575-583 Bath Road, Longford, Middlesex UB7 0EH, U.K.
U.S.A.	Marantz America Inc.	1100 Maplewood Drive Itasca, IL 60143, U.S.A.
YUGOSLAVIA	ITM Company	Omladinskih Brigada 86, 11070 Belgrade, Yugoslavia
EXPORT	Marantz Domestic Sales	A division of Marantz Europe BV,Building SFF2, P.O. Box 80002, 5600 JB Eindhoven, The Netherlands

www.marantz.com

Manufactured under license from Dolby Laboratories. "Dolby", "Pro Logic", and the double-D symbol are trademarks of Dolby Laboratories. Confidential unpublished works. Copyright 1992-1997 Dolby Laboratories. All rights reserved.

"DTS", "ES" and "DTS Digital Surround" are trademarks of Digital Theater Systems, Inc.